

unsteady-flow processes. During a *steady-flow process*, the fluid flows through the control volume steadily, experiencing no change with time at a fixed position. The mass and energy content of the control volume remain constant during a steady-flow process. Taking heat transfer *to* the system and work done *by* the system to be positive quantities, the conservation of mass and energy equations for steady-flow processes are expressed as

$$\sum_{\text{in}} \dot{m} = \sum_{\text{out}} \dot{m}$$

$$\dot{Q} - \dot{W} = \sum_{\text{out}} \dot{m} \left( h + \frac{V^2}{2} + gz \right) - \sum_{\text{in}} \dot{m} \left( h + \frac{V^2}{2} + gz \right)$$

for each exit for each inlet

These are the most general forms of the equations for steady-flow processes. For single-stream (one-inlet–one-exit) systems such as nozzles, diffusers, turbines, compressors, and pumps, they simplify to

$$\dot{m}_1 = \dot{m}_2 \rightarrow \frac{1}{v_1} V_1 A_1 = \frac{1}{v_2} V_2 A_2$$

$$\dot{Q} - \dot{W} = \dot{m} \left[ h_2 - h_1 + \frac{V_2^2 - V_1^2}{2} + g(z_2 - z_1) \right]$$

In these relations, subscripts 1 and 2 denote the inlet and exit states, respectively.

Most unsteady-flow processes can be modeled as a *uniform-flow process*, which requires that the fluid flow at any inlet or exit is uniform and steady, and thus the fluid properties do not change with time or position over the cross section of an inlet or exit. If they do, they are averaged and treated as constants for the entire process. When kinetic and potential energy changes associated with the control volume and the fluid streams are negligible, the mass and energy balance relations for a uniform-flow system are expressed as

$$m_{\text{in}} - m_{\text{out}} = \Delta m_{\text{system}}$$

$$Q - W = \sum_{\text{out}} mh - \sum_{\text{in}} mh + (m_2 u_2 - m_1 u_1)_{\text{system}}$$

where  $Q = Q_{\text{net,in}} = Q_{\text{in}} - Q_{\text{out}}$  is the net heat input and  $W = W_{\text{net,out}} = W_{\text{out}} - W_{\text{in}}$  is the net work output.

When solving thermodynamic problems, it is recommended that the general form of the energy balance  $E_{\text{in}} - E_{\text{out}} = \Delta E_{\text{system}}$  be used for all problems, and simplify it for the particular problem instead of using the specific relations given here for different processes.



## REFERENCES AND SUGGESTED READINGS

1. ASHRAE Handbook of Fundamentals. SI version. Atlanta, GA: American Society of Heating, Refrigerating, and Air-Conditioning Engineers, Inc., 1993.
2. ASHRAE Handbook of Refrigeration. SI version. Atlanta, GA: American Society of Heating, Refrigerating, and Air-Conditioning Engineers, Inc., 1994.
3. Y. A. Çengel and J. M. Cimbala, *Fluid Mechanics: Fundamentals and Applications*. New York: McGraw-Hill, 2006.

## PROBLEMS\*

### Conservation of Mass

**5-1C** Name four physical quantities that are conserved and two quantities that are not conserved during a process.

\*Problems designated by a “C” are concept questions, and students are encouraged to answer them all. Problems designated by an “E” are in English units, and the SI users can ignore them. Problems with a CD-EES icon  are solved using EES, and complete solutions together with parametric studies are included on the enclosed DVD. Problems with a computer-EES icon  are comprehensive in nature, and are intended to be solved with a computer, preferably using the EES software that accompanies this text.

**5-2C** Define mass and volume flow rates. How are they related to each other?

**5-3C** Does the amount of mass entering a control volume have to be equal to the amount of mass leaving during an unsteady-flow process?

**5-4C** When is the flow through a control volume steady?

**5-5C** Consider a device with one inlet and one outlet. If the volume flow rates at the inlet and at the outlet are the same, is the flow through this device necessarily steady? Why?

**5-6E** A garden hose attached with a nozzle is used to fill a 20-gal bucket. The inner diameter of the hose is 1 in and it

reduces to 0.5 in at the nozzle exit. If the average velocity in the hose is 8 ft/s, determine (a) the volume and mass flow rates of water through the hose, (b) how long it will take to fill the bucket with water, and (c) the average velocity of water at the nozzle exit.

**5-7** Air enters a nozzle steadily at  $2.21 \text{ kg/m}^3$  and  $40 \text{ m/s}$  and leaves at  $0.762 \text{ kg/m}^3$  and  $180 \text{ m/s}$ . If the inlet area of the nozzle is  $90 \text{ cm}^2$ , determine (a) the mass flow rate through the nozzle, and (b) the exit area of the nozzle. *Answers: (a)  $0.796 \text{ kg/s}$ , (b)  $58 \text{ cm}^2$*

**5-8** A hair dryer is basically a duct of constant diameter in which a few layers of electric resistors are placed. A small fan pulls the air in and forces it through the resistors where it is heated. If the density of air is  $1.20 \text{ kg/m}^3$  at the inlet and  $1.05 \text{ kg/m}^3$  at the exit, determine the percent increase in the velocity of air as it flows through the dryer.

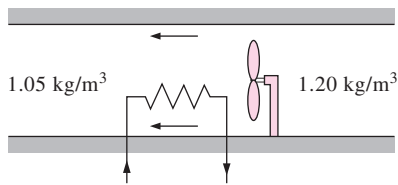

**FIGURE P5-8**

**5-9E** Air whose density is  $0.078 \text{ lbm/ft}^3$  enters the duct of an air-conditioning system at a volume flow rate of  $450 \text{ ft}^3/\text{min}$ . If the diameter of the duct is 10 in, determine the velocity of the air at the duct inlet and the mass flow rate of air.

**5-10** A  $1\text{-m}^3$  rigid tank initially contains air whose density is  $1.18 \text{ kg/m}^3$ . The tank is connected to a high-pressure supply line through a valve. The valve is opened, and air is allowed to enter the tank until the density in the tank rises to  $7.20 \text{ kg/m}^3$ . Determine the mass of air that has entered the tank. *Answer:  $6.02 \text{ kg}$*

**5-11** The ventilating fan of the bathroom of a building has a volume flow rate of  $30 \text{ L/s}$  and runs continuously. If the density of air inside is  $1.20 \text{ kg/m}^3$ , determine the mass of air vented out in one day.

**5-12** A desktop computer is to be cooled by a fan whose flow rate is  $0.34 \text{ m}^3/\text{min}$ . Determine the mass flow rate of air through the fan at an elevation of  $3400 \text{ m}$  where the air density is  $0.7 \text{ kg/m}^3$ . Also, if the average velocity of air is not to exceed  $110 \text{ m/min}$ , determine the diameter of the casing of the fan. *Answers:  $0.238 \text{ kg/min}$ ,  $0.063 \text{ m}$*

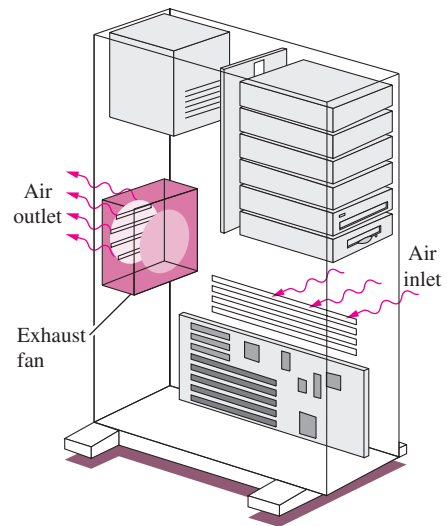

**FIGURE P5-12**

**5-13** A smoking lounge is to accommodate 15 heavy smokers. The minimum fresh air requirement for smoking lounges is specified to be  $30 \text{ L/s}$  per person (ASHRAE, Standard 62, 1989). Determine the minimum required flow rate of fresh air that needs to be supplied to the lounge, and the diameter of the duct if the air velocity is not to exceed  $8 \text{ m/s}$ .

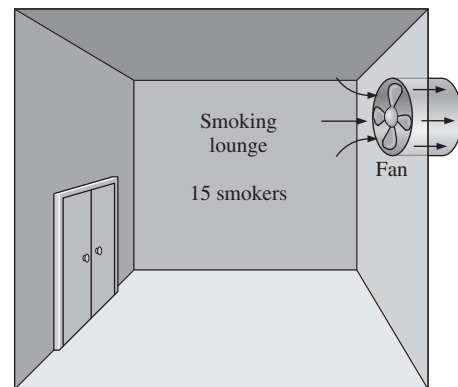

**FIGURE P5-13**

**5-14** The minimum fresh air requirement of a residential building is specified to be  $0.35$  air change per hour (ASHRAE, Standard 62, 1989). That is, 35 percent of the entire air contained in a residence should be replaced by fresh outdoor air every hour. If the ventilation requirement of a  $2.7\text{-m}$ -high,  $200\text{-m}^2$  residence is to be met entirely by a fan, determine the flow capacity in  $\text{L/min}$  of the fan that needs to be installed. Also determine the diameter of the duct if the air velocity is not to exceed  $6 \text{ m/s}$ .

**5–15** Air enters a 28-cm diameter pipe steadily at 200 kPa and 20°C with a velocity of 5 m/s. Air is heated as it flows, and leaves the pipe at 180 kPa and 40°C. Determine (a) the volume flow rate of air at the inlet, (b) the mass flow rate of air, and (c) the velocity and volume flow rate at the exit.

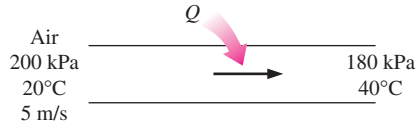

FIGURE P5–15

**5–16** Refrigerant-134a enters a 28-cm diameter pipe steadily at 200 kPa and 20°C with a velocity of 5 m/s. The refrigerant gains heat as it flows and leaves the pipe at 180 kPa and 40°C. Determine (a) the volume flow rate of the refrigerant at the inlet, (b) the mass flow rate of the refrigerant, and (c) the velocity and volume flow rate at the exit.

**5–17** Consider a 300-L storage tank of a solar water heating system initially filled with warm water at 45°C. Warm water is withdrawn from the tank through a 2-cm diameter hose at an average velocity of 0.5 m/s while cold water enters the tank at 20°C at a rate of 5 L/min. Determine the amount of water in the tank after a 20-minute period. Assume the pressure in the tank remains constant at 1 atm. *Answer: 212 kg*

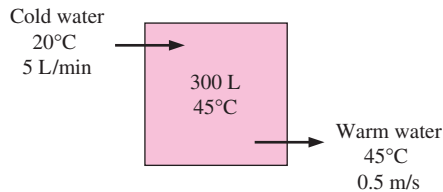

FIGURE P5–17

### Flow Work and Energy Transfer by Mass

**5–18C** What are the different mechanisms for transferring energy to or from a control volume?

**5–19C** What is flow energy? Do fluids at rest possess any flow energy?

**5–20C** How do the energies of a flowing fluid and a fluid at rest compare? Name the specific forms of energy associated with each case.

**5–21E** Steam is leaving a pressure cooker whose operating pressure is 30 psia. It is observed that the amount of liquid in the cooker has decreased by 0.4 gal in 45 minutes after the steady operating conditions are established, and the cross-sectional area of the exit opening is 0.15 in<sup>2</sup>. Determine (a) the mass flow rate of the steam and the exit velocity,

(b) the total and flow energies of the steam per unit mass, and (c) the rate at which energy is leaving the cooker by steam.

**5–22** Refrigerant-134a enters the compressor of a refrigeration system as saturated vapor at 0.14 MPa, and leaves as superheated vapor at 0.8 MPa and 60°C at a rate of 0.06 kg/s. Determine the rates of energy transfers by mass into and out of the compressor. Assume the kinetic and potential energies to be negligible.

**5–23** A house is maintained at 1 atm and 24°C, and warm air inside a house is forced to leave the house at a rate of 150 m<sup>3</sup>/h as a result of outdoor air at 5°C infiltrating into the house through the cracks. Determine the rate of net energy loss of the house due to mass transfer. *Answer: 0.945 kW*

**5–24** Air flows steadily in a pipe at 300 kPa, 77°C, and 25 m/s at a rate of 18 kg/min. Determine (a) the diameter of the pipe, (b) the rate of flow energy, (c) the rate of energy transport by mass, and (d) also determine the error involved in part (c) if the kinetic energy is neglected.

### Steady-Flow Energy Balance: Nozzles and Diffusers

**5–25C** How is a steady-flow system characterized?

**5–26C** Can a steady-flow system involve boundary work?

**5–27C** A diffuser is an adiabatic device that decreases the kinetic energy of the fluid by slowing it down. What happens to this *lost* kinetic energy?

**5–28C** The kinetic energy of a fluid increases as it is accelerated in an adiabatic nozzle. Where does this energy come from?

**5–29C** Is heat transfer to or from the fluid desirable as it flows through a nozzle? How will heat transfer affect the fluid velocity at the nozzle exit?

**5–30** Air enters an adiabatic nozzle steadily at 300 kPa, 200°C, and 30 m/s and leaves at 100 kPa and 180 m/s. The inlet area of the nozzle is 80 cm<sup>2</sup>. Determine (a) the mass flow rate through the nozzle, (b) the exit temperature of the air, and (c) the exit area of the nozzle. *Answers: (a) 0.5304 kg/s, (b) 184.6°C, (c) 38.7 cm<sup>2</sup>*

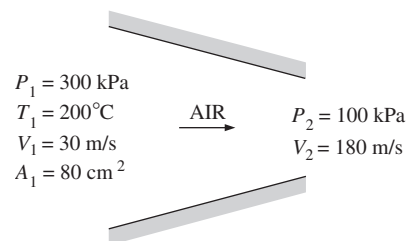



FIGURE P5–30

**5-31**  Reconsider Prob. 5-30. Using EES (or other) software, investigate the effect of the inlet area on the mass flow rate, exit temperature, and the exit area. Let the inlet area vary from 50 cm<sup>2</sup> to 150 cm<sup>2</sup>. Plot the final results against the inlet area, and discuss the results.

**5-32** Steam at 5 MPa and 400°C enters a nozzle steadily with a velocity of 80 m/s, and it leaves at 2 MPa and 300°C. The inlet area of the nozzle is 50 cm<sup>2</sup>, and heat is being lost at a rate of 120 kJ/s. Determine (a) the mass flow rate of the steam, (b) the exit velocity of the steam, and (c) the exit area of the nozzle.

**5-33E** Air enters a nozzle steadily at 50 psia, 140°F, and 150 ft/s and leaves at 14.7 psia and 900 ft/s. The heat loss from the nozzle is estimated to be 6.5 Btu/lbm of air flowing. The inlet area of the nozzle is 0.1 ft<sup>2</sup>. Determine (a) the exit temperature of air and (b) the exit area of the nozzle.  
*Answers: (a) 507 R, (b) 0.048 ft<sup>2</sup>*

**5-34**  Steam at 3 MPa and 400°C enters an adiabatic nozzle steadily with a velocity of 40 m/s and leaves at 2.5 MPa and 300 m/s. Determine (a) the exit temperature and (b) the ratio of the inlet to exit area  $A_1/A_2$ .

**5-35** Air at 600 kPa and 500 K enters an adiabatic nozzle that has an inlet-to-exit area ratio of 2:1 with a velocity of

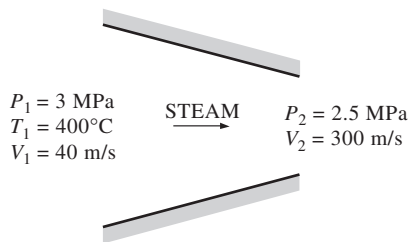

**FIGURE P5-34**

120 m/s and leaves with a velocity of 380 m/s. Determine (a) the exit temperature and (b) the exit pressure of the air.  
*Answers: (a) 436.5 K, (b) 330.8 kPa*

**5-36** Air at 80 kPa and 127°C enters an adiabatic diffuser steadily at a rate of 6000 kg/h and leaves at 100 kPa. The velocity of the airstream is decreased from 230 to 30 m/s as it passes through the diffuser. Find (a) the exit temperature of the air and (b) the exit area of the diffuser.

**5-37E** Air at 13 psia and 20°F enters an adiabatic diffuser steadily with a velocity of 600 ft/s and leaves with a low velocity at a pressure of 14.5 psia. The exit area of the diffuser is 5 times the inlet area. Determine (a) the exit temperature and (b) the exit velocity of the air.

**5-38** Carbon dioxide enters an adiabatic nozzle steadily at 1 MPa and 500°C with a mass flow rate of 6000 kg/h and

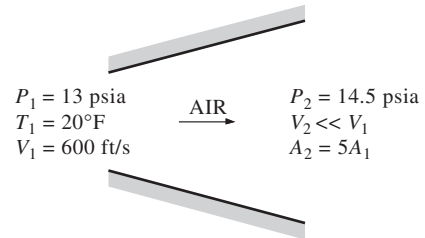

**FIGURE P5-37E**

leaves at 100 kPa and 450 m/s. The inlet area of the nozzle is 40 cm<sup>2</sup>. Determine (a) the inlet velocity and (b) the exit temperature.  
*Answers: (a) 60.8 m/s, (b) 685.8 K*

**5-39** Refrigerant-134a at 700 kPa and 120°C enters an adiabatic nozzle steadily with a velocity of 20 m/s and leaves at 400 kPa and 30°C. Determine (a) the exit velocity and (b) the ratio of the inlet to exit area  $A_1/A_2$ .

**5-40** Air at 80 kPa, 27°C, and 220 m/s enters a diffuser at a rate of 2.5 kg/s and leaves at 42°C. The exit area of the diffuser is 400 cm<sup>2</sup>. The air is estimated to lose heat at a rate of 18 kJ/s during this process. Determine (a) the exit velocity and (b) the exit pressure of the air.  
*Answers: (a) 62.0 m/s, (b) 91.1 kPa*

**5-41** Nitrogen gas at 60 kPa and 7°C enters an adiabatic diffuser steadily with a velocity of 200 m/s and leaves at 85 kPa and 22°C. Determine (a) the exit velocity of the nitrogen and (b) the ratio of the inlet to exit area  $A_1/A_2$ .

**5-42**  Reconsider Prob. 5-41. Using EES (or other) software, investigate the effect of the inlet velocity on the exit velocity and the ratio of the inlet-to-exit area. Let the inlet velocity vary from 180 to 260 m/s. Plot the final results against the inlet velocity, and discuss the results.

**5-43** Refrigerant-134a enters a diffuser steadily as saturated vapor at 800 kPa with a velocity of 120 m/s, and it leaves at 900 kPa and 40°C. The refrigerant is gaining heat at a rate of 2 kJ/s as it passes through the diffuser. If the exit area is 80 percent greater than the inlet area, determine (a) the exit velocity and (b) the mass flow rate of the refrigerant.  
*Answers: (a) 60.8 m/s, (b) 1.308 kg/s*

**5-44** Steam enters a nozzle at 400°C and 800 kPa with a velocity of 10 m/s, and leaves at 300°C and 200 kPa while losing heat at a rate of 25 kW. For an inlet area of 800 cm<sup>2</sup>, determine the velocity and the volume flow rate of the steam at the nozzle exit.  
*Answers: 606 m/s, 2.74 m<sup>3</sup>/s*

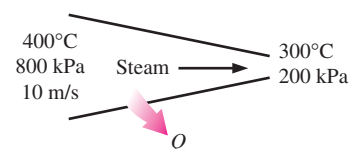

**FIGURE P5-44**

## Turbines and Compressors

**5-45C** Consider an adiabatic turbine operating steadily. Does the work output of the turbine have to be equal to the decrease in the energy of the steam flowing through it?

**5-46C** Consider an air compressor operating steadily. How would you compare the volume flow rates of the air at the compressor inlet and exit?

**5-47C** Will the temperature of air rise as it is compressed by an adiabatic compressor? Why?

**5-48C** Somebody proposes the following system to cool a house in the summer: Compress the regular outdoor air, let it cool back to the outdoor temperature, pass it through a turbine, and discharge the cold air leaving the turbine into the house. From a thermodynamic point of view, is the proposed system sound?

**5-49** Steam flows steadily through an adiabatic turbine. The inlet conditions of the steam are 10 MPa, 450°C, and 80 m/s, and the exit conditions are 10 kPa, 92 percent quality, and 50 m/s. The mass flow rate of the steam is 12 kg/s. Determine (a) the change in kinetic energy, (b) the power output, and (c) the turbine inlet area. *Answers: (a) -1.95 kJ/kg, (b) 10.2 MW, (c) 0.00447 m<sup>2</sup>*

**5-50**  Reconsider Prob. 5-49. Using EES (or other) software, investigate the effect of the turbine exit

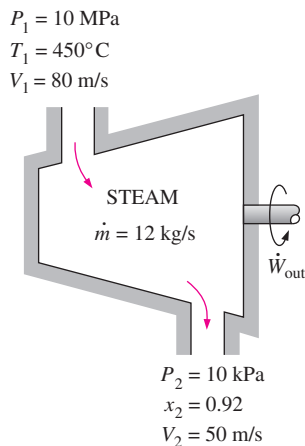

FIGURE P5-49

pressure on the power output of the turbine. Let the exit pressure vary from 10 to 200 kPa. Plot the power output against the exit pressure, and discuss the results.

**5-51** Steam enters an adiabatic turbine at 10 MPa and 500°C and leaves at 10 kPa with a quality of 90 percent. Neglecting the changes in kinetic and potential energies, determine the mass flow rate required for a power output of 5 MW. *Answer: 4.852 kg/s*

**5-52E** Steam flows steadily through a turbine at a rate of 45,000 lbm/h, entering at 1000 psia and 900°F and leaving at 5 psia as saturated vapor. If the power generated by the turbine is 4 MW, determine the rate of heat loss from the steam.

**5-53** Steam enters an adiabatic turbine at 8 MPa and 500°C at a rate of 3 kg/s and leaves at 20 kPa. If the power output of the turbine is 2.5 MW, determine the temperature of the steam at the turbine exit. Neglect kinetic energy changes. *Answer: 60.1°C*

**5-54** Argon gas enters an adiabatic turbine steadily at 900 kPa and 450°C with a velocity of 80 m/s and leaves at 150 kPa with a velocity of 150 m/s. The inlet area of the turbine is 60 cm<sup>2</sup>. If the power output of the turbine is 250 kW, determine the exit temperature of the argon.

**5-55E** Air flows steadily through an adiabatic turbine, entering at 150 psia, 900°F, and 350 ft/s and leaving at 20 psia,

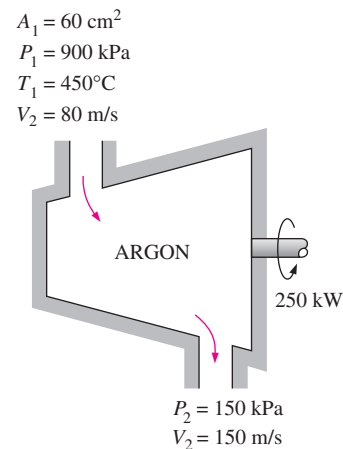

FIGURE P5-54

300°F, and 700 ft/s. The inlet area of the turbine is 0.1 ft<sup>2</sup>. Determine (a) the mass flow rate of the air and (b) the power output of the turbine.

**5-56** Refrigerant-134a enters an adiabatic compressor as saturated vapor at -24°C and leaves at 0.8 MPa and 60°C. The mass flow rate of the refrigerant is 1.2 kg/s. Determine (a) the power input to the compressor and (b) the volume flow rate of the refrigerant at the compressor inlet.

**5-57** Air enters the compressor of a gas-turbine plant at ambient conditions of 100 kPa and 25°C with a low velocity and exits at 1 MPa and 347°C with a velocity of 90 m/s. The compressor is cooled at a rate of 1500 kJ/min, and the power input to the compressor is 250 kW. Determine the mass flow rate of air through the compressor.

**5-58E** Air is compressed from 14.7 psia and 60°F to a pressure of 150 psia while being cooled at a rate of 10 Btu/lbm by

circulating water through the compressor casing. The volume flow rate of the air at the inlet conditions is 5000 ft<sup>3</sup>/min, and the power input to the compressor is 700 hp. Determine (a) the mass flow rate of the air and (b) the temperature at the compressor exit. *Answers: (a) 6.36 lbm/s, (b) 801 R*

**5-59E**  Reconsider Prob. 5-58E. Using EES (or other) software, investigate the effect of the rate of cooling of the compressor on the exit temperature of air. Let the cooling rate vary from 0 to 100 Btu/lbm. Plot the air exit temperature against the rate of cooling, and discuss the results.

**5-60** Helium is to be compressed from 120 kPa and 310 K to 700 kPa and 430 K. A heat loss of 20 kJ/kg occurs during the compression process. Neglecting kinetic energy changes, determine the power input required for a mass flow rate of 90 kg/min.

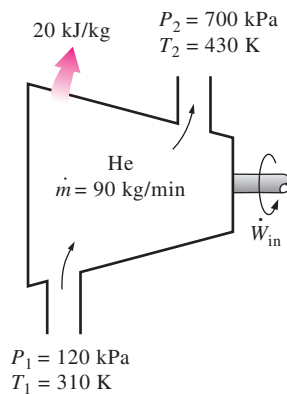

FIGURE P5-60

**5-61** Carbon dioxide enters an adiabatic compressor at 100 kPa and 300 K at a rate of 0.5 kg/s and leaves at 600 kPa and 450 K. Neglecting kinetic energy changes, determine (a) the volume flow rate of the carbon dioxide at the compressor inlet and (b) the power input to the compressor.

*Answers: (a) 0.28 m<sup>3</sup>/s, (b) 68.8 kW*

### Throttling Valves

**5-62C** Why are throttling devices commonly used in refrigeration and air-conditioning applications?

**5-63C** During a throttling process, the temperature of a fluid drops from 30 to  $-20^{\circ}\text{C}$ . Can this process occur adiabatically?

**5-64C** Would you expect the temperature of air to drop as it undergoes a steady-flow throttling process? Explain.

**5-65C** Would you expect the temperature of a liquid to change as it is throttled? Explain.

**5-66** Refrigerant-134a is throttled from the saturated liquid state at 700 kPa to a pressure of 160 kPa. Determine the temperature drop during this process and the final specific volume of the refrigerant. *Answers: 42.3°C, 0.0344 m<sup>3</sup>/kg*

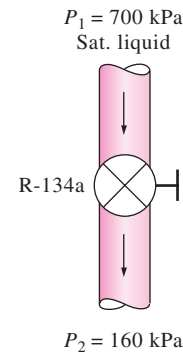



FIGURE P5-66

**5-67**  Refrigerant-134a at 800 kPa and  $25^{\circ}\text{C}$  is throttled to a temperature of  $-20^{\circ}\text{C}$ . Determine the pressure and the internal energy of the refrigerant at the final state. *Answers: 133 kPa, 80.7 kJ/kg*

**5-68** A well-insulated valve is used to throttle steam from 8 MPa and  $500^{\circ}\text{C}$  to 6 MPa. Determine the final temperature of the steam. *Answer: 490.1°C*

**5-69**  Reconsider Prob. 5-68. Using EES (or other) software, investigate the effect of the exit pressure of steam on the exit temperature after throttling. Let the exit pressure vary from 6 to 1 MPa. Plot the exit temperature of steam against the exit pressure, and discuss the results.

**5-70E** Air at 200 psia and  $90^{\circ}\text{F}$  is throttled to the atmospheric pressure of 14.7 psia. Determine the final temperature of the air.

**5-71** Carbon dioxide gas enters a throttling valve at 5 MPa and  $100^{\circ}\text{C}$  and leaves at 100 kPa. Determine the temperature change during this process if CO<sub>2</sub> is assumed to be (a) an ideal gas and (b) a real gas.

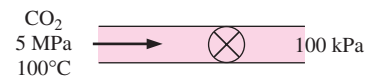

FIGURE P5-71

### Mixing Chambers and Heat Exchangers

**5-72C** When two fluid streams are mixed in a mixing chamber, can the mixture temperature be lower than the temperature of both streams? Explain.

**5-73C** Consider a steady-flow mixing process. Under what conditions will the energy transported into the control volume

by the incoming streams be equal to the energy transported out of it by the outgoing stream?

**5-74C** Consider a steady-flow heat exchanger involving two different fluid streams. Under what conditions will the amount of heat lost by one fluid be equal to the amount of heat gained by the other?

**5-75** A hot-water stream at 80°C enters a mixing chamber with a mass flow rate of 0.5 kg/s where it is mixed with a stream of cold water at 20°C. If it is desired that the mixture leave the chamber at 42°C, determine the mass flow rate of the cold-water stream. Assume all the streams are at a pressure of 250 kPa. *Answer: 0.865 kg/s*

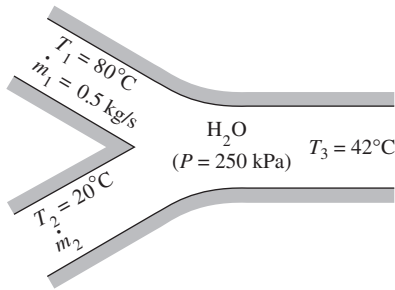

FIGURE P5-75

**5-76** Liquid water at 300 kPa and 20°C is heated in a chamber by mixing it with superheated steam at 300 kPa and 300°C. Cold water enters the chamber at a rate of 1.8 kg/s. If the mixture leaves the mixing chamber at 60°C, determine the mass flow rate of the superheated steam required. *Answer: 0.107 kg/s*

**5-77** In steam power plants, open feedwater heaters are frequently utilized to heat the feedwater by mixing it with steam bled off the turbine at some intermediate stage. Consider an open feedwater heater that operates at a pressure of 1000 kPa. Feedwater at 50°C and 1000 kPa is to be heated with superheated steam at 200°C and 1000 kPa. In an ideal feedwater heater, the mixture leaves the heater as saturated liquid at the feedwater pressure. Determine the ratio of the mass flow rates of the feedwater and the superheated vapor for this case. *Answer: 3.73*

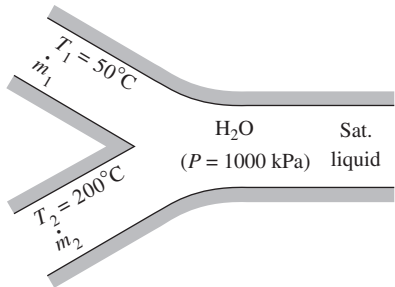



FIGURE P5-77

**5-78E** Water at 50°F and 50 psia is heated in a chamber by mixing it with saturated water vapor at 50 psia. If both streams enter the mixing chamber at the same mass flow rate, determine the temperature and the quality of the exiting stream. *Answers: 281°F, 0.374*

**5-79** A stream of refrigerant-134a at 1 MPa and 12°C is mixed with another stream at 1 MPa and 60°C. If the mass flow rate of the cold stream is twice that of the hot one, determine the temperature and the quality of the exit stream.

**5-80**  Reconsider Prob. 5-79. Using EES (or other) software, investigate the effect of the mass flow rate of the cold stream of R-134a on the temperature and the quality of the exit stream. Let the ratio of the mass flow rate of the cold stream to that of the hot stream vary from 1 to 4. Plot the mixture temperature and quality against the cold-to-hot mass flow rate ratio, and discuss the results.

**5-81** Refrigerant-134a at 1 MPa and 90°C is to be cooled to 1 MPa and 30°C in a condenser by air. The air enters at 100 kPa and 27°C with a volume flow rate of 600 m³/min and leaves at 95 kPa and 60°C. Determine the mass flow rate of the refrigerant. *Answer: 100 kg/min*

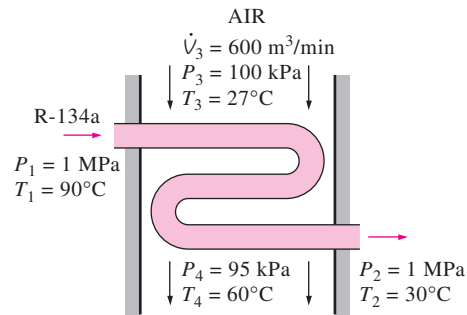



FIGURE P5-81

**5-82E** Air enters the evaporator section of a window air conditioner at 14.7 psia and 90°F with a volume flow rate of 200 ft³/min. Refrigerant-134a at 20 psia with a quality of 30 percent enters the evaporator at a rate of 4 lbm/min and leaves as saturated vapor at the same pressure. Determine (a) the exit temperature of the air and (b) the rate of heat transfer from the air.

**5-83** Refrigerant-134a at 700 kPa, 70°C, and 8 kg/min is cooled by water in a condenser until it exists as a saturated liquid at the same pressure. The cooling water enters the condenser at 300 kPa and 15°C and leaves at 25°C at the same pressure. Determine the mass flow rate of the cooling water required to cool the refrigerant. *Answer: 42.0 kg/min*

**5-84E**  In a steam heating system, air is heated by being passed over some tubes through which steam flows steadily. Steam enters the heat exchanger at 30 psia and 400°F at a rate of 15 lbm/min and leaves at 25 psia

and 212°F. Air enters at 14.7 psia and 80°F and leaves at 130°F. Determine the volume flow rate of air at the inlet.

**5-85** Steam enters the condenser of a steam power plant at 20 kPa and a quality of 95 percent with a mass flow rate of 20,000 kg/h. It is to be cooled by water from a nearby river by circulating the water through the tubes within the condenser. To prevent thermal pollution, the river water is not allowed to experience a temperature rise above 10°C. If the steam is to leave the condenser as saturated liquid at 20 kPa, determine the mass flow rate of the cooling water required.

*Answer: 297.7 kg/s*

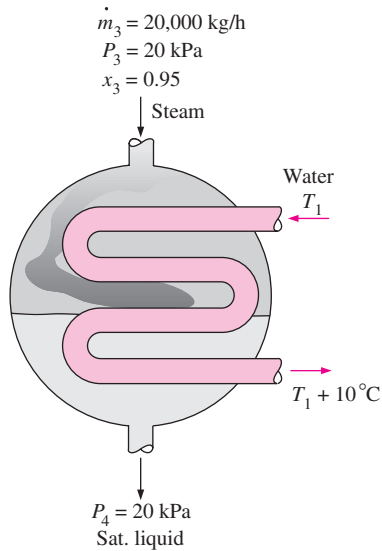

**FIGURE P5-85**

**5-86** Steam is to be condensed in the condenser of a steam power plant at a temperature of 50°C with cooling water

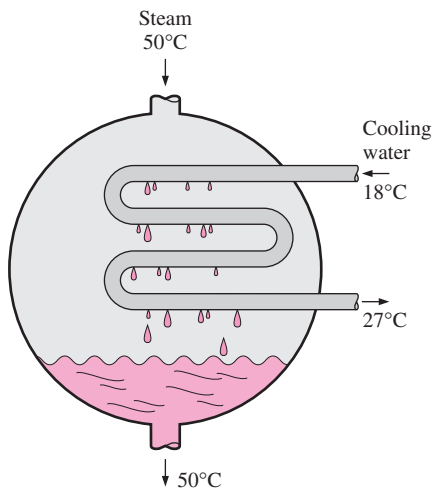

**FIGURE P5-86**

from a nearby lake, which enters the tubes of the condenser at 18°C at a rate of 101 kg/s and leaves at 27°C. Determine the rate of condensation of the steam in the condenser.

*Answer: 1.60 kg/s*

**5-87**  Reconsider Prob. 5-86. Using EES (or other) software, investigate the effect of the inlet temperature of cooling water on the rate of condensation of steam. Let the inlet temperature vary from 10 to 20°C, and assume the exit temperature to remain constant. Plot the rate of condensation of steam against the inlet temperature of the cooling water, and discuss the results.

**5-88** A heat exchanger is to heat water ( $c_p = 4.18 \text{ kJ/kg} \cdot ^\circ\text{C}$ ) from 25 to 60°C at a rate of 0.2 kg/s. The heating is to be accomplished by geothermal water ( $c_p = 4.31 \text{ kJ/kg} \cdot ^\circ\text{C}$ ) available at 140°C at a mass flow rate of 0.3 kg/s. Determine the rate of heat transfer in the heat exchanger and the exit temperature of geothermal water.

**5-89** A heat exchanger is to cool ethylene glycol ( $c_p = 2.56 \text{ kJ/kg} \cdot ^\circ\text{C}$ ) flowing at a rate of 2 kg/s from 80°C to 40°C by water ( $c_p = 4.18 \text{ kJ/kg} \cdot ^\circ\text{C}$ ) that enters at 20°C and leaves at 55°C. Determine (a) the rate of heat transfer and (b) the mass flow rate of water.

**5-90**  Reconsider Prob. 5-89. Using EES (or other) software, investigate the effect of the inlet temperature of cooling water on the mass flow rate of water. Let the inlet temperature vary from 10 to 40°C, and assume the exit temperature to remain constant. Plot the mass flow rate of water against the inlet temperature, and discuss the results.

**5-91** A thin-walled double-pipe counter-flow heat exchanger is used to cool oil ( $c_p = 2.20 \text{ kJ/kg} \cdot ^\circ\text{C}$ ) from 150 to 40°C at a rate of 2 kg/s by water ( $c_p = 4.18 \text{ kJ/kg} \cdot ^\circ\text{C}$ ) that enters at 22°C at a rate of 1.5 kg/s. Determine the rate of heat transfer in the heat exchanger and the exit temperature of water.

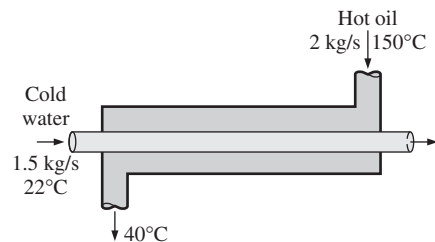

**FIGURE P5-91**

**5-92** Cold water ( $c_p = 4.18 \text{ kJ/kg} \cdot ^\circ\text{C}$ ) leading to a shower enters a thin-walled double-pipe counter-flow heat exchanger at 15°C at a rate of 0.60 kg/s and is heated to 45°C by hot water ( $c_p = 4.19 \text{ kJ/kg} \cdot ^\circ\text{C}$ ) that enters at 100°C at a rate of 3 kg/s. Determine the rate of heat transfer in the heat exchanger and the exit temperature of the hot water.

**5-93** Air ( $c_p = 1.005 \text{ kJ/kg} \cdot ^\circ\text{C}$ ) is to be preheated by hot exhaust gases in a cross-flow heat exchanger before it enters

the furnace. Air enters the heat exchanger at 95 kPa and 20°C at a rate of 0.8 m<sup>3</sup>/s. The combustion gases ( $c_p = 1.10 \text{ kJ/kg} \cdot ^\circ\text{C}$ ) enter at 180°C at a rate of 1.1 kg/s and leave at 95°C. Determine the rate of heat transfer to the air and its outlet temperature.

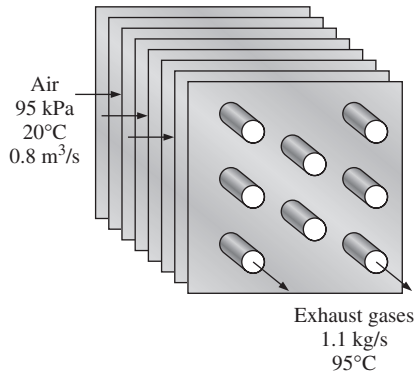

FIGURE P5-93

**5-94** A well-insulated shell-and-tube heat exchanger is used to heat water ( $c_p = 4.18 \text{ kJ/kg} \cdot ^\circ\text{C}$ ) in the tubes from 20 to 70°C at a rate of 4.5 kg/s. Heat is supplied by hot oil ( $c_p = 2.30 \text{ kJ/kg} \cdot ^\circ\text{C}$ ) that enters the shell side at 170°C at a rate of 10 kg/s. Determine the rate of heat transfer in the heat exchanger and the exit temperature of oil.

**5-95E** Steam is to be condensed on the shell side of a heat exchanger at 85°F. Cooling water enters the tubes at 60°F at a rate of 138 lbm/s and leaves at 73°F. Assuming the heat exchanger to be well-insulated, determine the rate of heat transfer in the heat exchanger and the rate of condensation of the steam.

**5-96** An air-conditioning system involves the mixing of cold air and warm outdoor air before the mixture is routed to the conditioned room in steady operation. Cold air enters the mixing chamber at 5°C and 105 kPa at a rate of 1.25 m<sup>3</sup>/s while warm air enters at 34°C and 105 kPa. The air leaves the room at 24°C. The ratio of the mass flow rates of the hot to cold air streams is 1.6. Using variable specific heats, determine (a) the mixture temperature at the inlet of the room and (b) the rate of heat gain of the room.

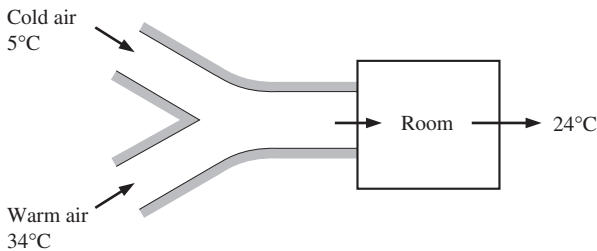

FIGURE P5-96

**5-97** Hot exhaust gases of an internal combustion engine are to be used to produce saturated water vapor at 2 MPa pressure. The exhaust gases enter the heat exchanger at 400°C at a rate of 32 kg/min while water enters at 15°C. The heat exchanger is not well insulated, and it is estimated that 10 percent of heat given up by the exhaust gases is lost to the surroundings. If the mass flow rate of the exhaust gases is 15 times that of the water, determine (a) the temperature of the exhaust gases at the heat exchanger exit and (b) the rate of heat transfer to the water. Use the constant specific heat properties of air for the exhaust gases.

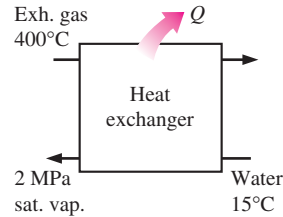

FIGURE P5-97

**Pipe and Duct Flow**

**5-98** A desktop computer is to be cooled by a fan. The electronic components of the computer consume 60 W of power under full-load conditions. The computer is to operate in environments at temperatures up to 45°C and at elevations up to 3400 m where the average atmospheric pressure is 66.63 kPa. The exit temperature of air is not to exceed 60°C to meet the reliability requirements. Also, the average velocity of air is not to exceed 110 m/min at the exit of the computer case where the fan is installed to keep the noise level down. Determine the flow rate of the fan that needs to be installed and the diameter of the casing of the fan.

**5-99** Repeat Prob. 5-98 for a computer that consumes 100 W of power.

**5-100E** Water enters the tubes of a cold plate at 95°F with an average velocity of 60 ft/min and leaves at 105°F. The diameter of the tubes is 0.25 in. Assuming 15 percent of the heat generated is dissipated from the components to the surroundings by convection and radiation, and the remaining 85 percent is removed by the cooling water, determine the amount of heat generated by the electronic devices mounted on the cold plate. *Answer: 263 W*

**5-101** A sealed electronic box is to be cooled by tap water flowing through the channels on two of its sides. It is specified that the temperature rise of the water not exceed 4°C. The power dissipation of the box is 2 kW, which is removed entirely by water. If the box operates 24 hours a day, 365 days a year, determine the mass flow rate of water flowing through the box and the amount of cooling water used per year.

**5-102** Repeat Prob. 5-101 for a power dissipation of 4 kW.

**5–103** A long roll of 2-m-wide and 0.5-cm-thick 1-Mn manganese steel plate ( $\rho = 7854 \text{ kg/m}^3$  and  $c_p = 0.434 \text{ kJ/kg} \cdot ^\circ\text{C}$ ) coming off a furnace at  $820^\circ\text{C}$  is to be quenched in an oil bath at  $45^\circ\text{C}$  to a temperature of  $51.1^\circ\text{C}$ . If the metal sheet is moving at a steady velocity of  $10 \text{ m/min}$ , determine the required rate of heat removal from the oil to keep its temperature constant at  $45^\circ\text{C}$ . *Answer: 4368 kW*

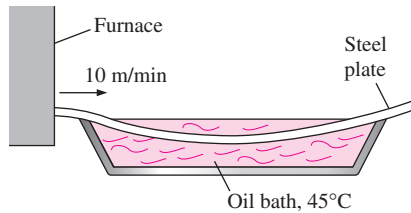

**FIGURE P5–103**

**5–104**  Reconsider Prob. 5–103. Using EES (or other) software, investigate the effect of the moving velocity of the steel plate on the rate of heat transfer from the oil bath. Let the velocity vary from 5 to 50 m/min. Plot the rate of heat transfer against the plate velocity, and discuss the results.

**5–105**  The components of an electronic system dissipating  $180 \text{ W}$  are located in a  $1.4\text{-m}$ -long horizontal duct whose cross section is  $20 \text{ cm} \times 20 \text{ cm}$ . The components in the duct are cooled by forced air that enters the duct at  $30^\circ\text{C}$  and  $1 \text{ atm}$  at a rate of  $0.6 \text{ m}^3/\text{min}$  and leaves at  $40^\circ\text{C}$ . Determine the rate of heat transfer from the outer surfaces of the duct to the ambient. *Answer: 63 W*

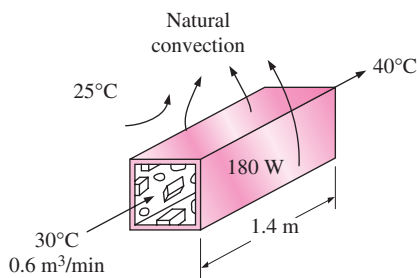

**FIGURE P5–105**

**5–106** Repeat Prob. 5–105 for a circular horizontal duct of diameter  $10 \text{ cm}$ .

**5–107E** The hot-water needs of a household are to be met by heating water at  $55^\circ\text{F}$  to  $180^\circ\text{F}$  by a parabolic solar collector at a rate of  $4 \text{ lbm/s}$ . Water flows through a  $1.25\text{-in}$ -diameter thin aluminum tube whose outer surface is black-anodized in order to maximize its solar absorption ability. The centerline of the tube coincides with the focal line of the collector, and a glass sleeve is placed outside the tube to minimize the heat losses. If solar energy is transferred to water at a net rate of

$400 \text{ Btu/h}$  per ft length of the tube, determine the required length of the parabolic collector to meet the hot-water requirements of this house.

**5–108** Consider a hollow-core printed circuit board  $12 \text{ cm}$  high and  $18 \text{ cm}$  long, dissipating a total of  $20 \text{ W}$ . The width of the air gap in the middle of the PCB is  $0.25 \text{ cm}$ . If the cooling air enters the  $12\text{-cm}$ -wide core at  $32^\circ\text{C}$  and  $1 \text{ atm}$  at a rate of  $0.8 \text{ L/s}$ , determine the average temperature at which the air leaves the hollow core. *Answer: 53.4°C*

**5–109** A computer cooled by a fan contains eight PCBs, each dissipating  $10 \text{ W}$  power. The height of the PCBs is  $12 \text{ cm}$  and the length is  $18 \text{ cm}$ . The cooling air is supplied by a  $25\text{-W}$  fan mounted at the inlet. If the temperature rise of air as it flows through the case of the computer is not to exceed  $10^\circ\text{C}$ , determine (a) the flow rate of the air that the fan needs to deliver and (b) the fraction of the temperature rise of air that is due to the heat generated by the fan and its motor. *Answers: (a) 0.0104 kg/s, (b) 24 percent*

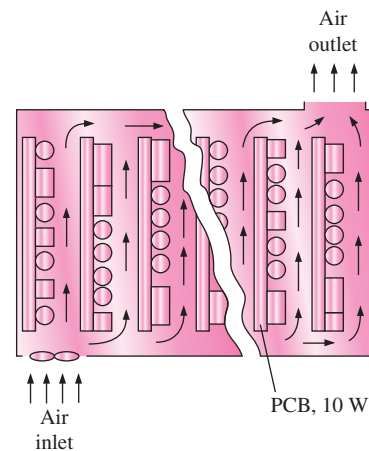

**FIGURE P5–109**

**5–110** Hot water at  $90^\circ\text{C}$  enters a  $15\text{-m}$  section of a cast iron pipe whose inner diameter is  $4 \text{ cm}$  at an average velocity of  $0.8 \text{ m/s}$ . The outer surface of the pipe is exposed to the cold air at  $10^\circ\text{C}$  in a basement. If water leaves the basement at  $88^\circ\text{C}$ , determine the rate of heat loss from the water.

**5–111**  Reconsider Prob. 5–110. Using EES (or other) software, investigate the effect of the inner pipe diameter on the rate of heat loss. Let the pipe diameter vary from  $1.5$  to  $7.5 \text{ cm}$ . Plot the rate of heat loss against the diameter, and discuss the results.

**5–112** A  $5\text{-m} \times 6\text{-m} \times 8\text{-m}$  room is to be heated by an electric resistance heater placed in a short duct in the room. Initially, the room is at  $15^\circ\text{C}$ , and the local atmospheric pressure is  $98 \text{ kPa}$ . The room is losing heat steadily to the outside at a rate of  $200 \text{ kJ/min}$ . A  $200\text{-W}$  fan circulates the air steadily through the duct and the electric heater at an average

mass flow rate of 50 kg/min. The duct can be assumed to be adiabatic, and there is no air leaking in or out of the room. If it takes 15 min for the room air to reach an average temperature of 25°C, find (a) the power rating of the electric heater and (b) the temperature rise that the air experiences each time it passes through the heater.

**5-113** A house has an electric heating system that consists of a 300-W fan and an electric resistance heating element placed in a duct. Air flows steadily through the duct at a rate of 0.6 kg/s and experiences a temperature rise of 7°C. The rate of heat loss from the air in the duct is estimated to be 300 W. Determine the power rating of the electric resistance heating element. *Answer: 4.22 kW*

**5-114** A hair dryer is basically a duct in which a few layers of electric resistors are placed. A small fan pulls the air in and forces it through the resistors where it is heated. Air enters a 1200-W hair dryer at 100 kPa and 22°C and leaves at 47°C. The cross-sectional area of the hair dryer at the exit is 60 cm<sup>2</sup>. Neglecting the power consumed by the fan and the heat losses through the walls of the hair dryer, determine (a) the volume flow rate of air at the inlet and (b) the velocity of the air at the exit. *Answers: (a) 0.0404 m<sup>3</sup>/s, (b) 7.31 m/s*

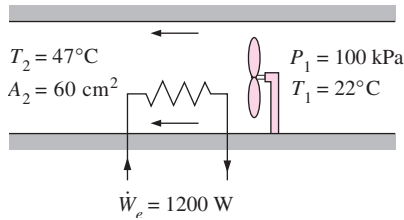



FIGURE P5-114

**5-115**  Reconsider Prob. 5-114. Using EES (or other) software, investigate the effect of the exit cross-sectional area of the hair dryer on the exit velocity. Let the exit area vary from 25 to 75 cm<sup>2</sup>. Plot the exit velocity against the exit cross-sectional area, and discuss the results. Include the effect of the flow kinetic energy in the analysis.

**5-116** The ducts of an air heating system pass through an unheated area. As a result of heat losses, the temperature of the air in the duct drops by 4°C. If the mass flow rate of air is 120 kg/min, determine the rate of heat loss from the air to the cold environment.

**5-117E** Air enters the duct of an air-conditioning system at 15 psia and 50°F at a volume flow rate of 450 ft<sup>3</sup>/min. The diameter of the duct is 10 in, and heat is transferred to the air in the duct from the surroundings at a rate of 2 Btu/s. Determine (a) the velocity of the air at the duct inlet and (b) the temperature of the air at the exit.

**5-118** Water is heated in an insulated, constant-diameter tube by a 7-kW electric resistance heater. If the water enters

the heater steadily at 20°C and leaves at 75°C, determine the mass flow rate of water.

**5-119** Steam enters a long, horizontal pipe with an inlet diameter of  $D_1 = 12$  cm at 1 MPa and 300°C with a velocity of 2 m/s. Farther downstream, the conditions are 800 kPa and 250°C, and the diameter is  $D_2 = 10$  cm. Determine (a) the mass flow rate of the steam and (b) the rate of heat transfer. *Answers: (a) 0.0877 kg/s, (b) 8.87 kJ/s*

**5-120** Steam enters an insulated pipe at 200 kPa and 200°C and leaves at 150 kPa and 150°C. The inlet-to-outlet diameter ratio for the pipe is  $D_1/D_2 = 1.80$ . Determine the inlet and exit velocities of the steam.

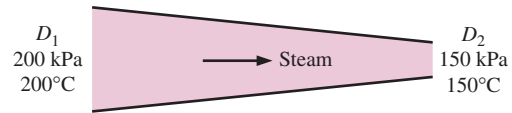

FIGURE P5-120

**Charging and Discharging Processes**

**5-121** A balloon that initially contains 50 m<sup>3</sup> of steam at 100 kPa and 150°C is connected by a valve to a large reservoir that supplies steam at 150 kPa and 200°C. Now the valve is opened, and steam is allowed to enter the balloon until the pressure equilibrium with the steam at the supply line is reached. The material of the balloon is such that its volume increases linearly with pressure. Heat transfer also takes place between the balloon and the surroundings, and the mass of the steam in the balloon doubles at the end of the process. Determine the final temperature and the boundary work during this process.

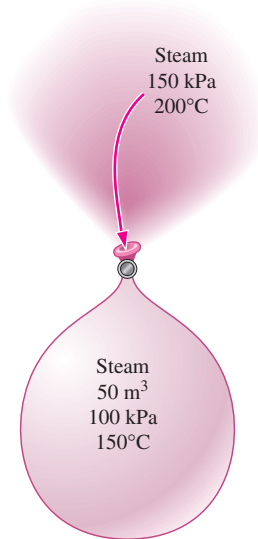

FIGURE P5-121

**5-122** A rigid, insulated tank that is initially evacuated is connected through a valve to a supply line that carries steam at 4 MPa. Now the valve is opened, and steam is allowed to flow into the tank until the pressure reaches 4 MPa, at which point the valve is closed. If the final temperature of the steam in the tank is 550°C, determine the temperature of the steam in the supply line and the flow work per unit mass of the steam.

**5-123** A vertical piston–cylinder device initially contains 0.25 m<sup>3</sup> of air at 600 kPa and 300°C. A valve connected to the cylinder is now opened, and air is allowed to escape until three-quarters of the mass leave the cylinder at which point the volume is 0.05 m<sup>3</sup>. Determine the final temperature in the cylinder and the boundary work during this process.

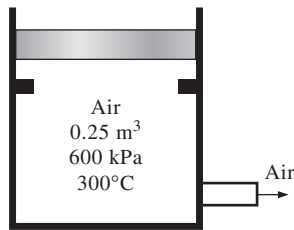

FIGURE P5-123

**5-124** A rigid, insulated tank that is initially evacuated is connected through a valve to a supply line that carries helium at 200 kPa and 120°C. Now the valve is opened, and helium is allowed to flow into the tank until the pressure reaches 200 kPa, at which point the valve is closed. Determine the flow work of the helium in the supply line and the final temperature of the helium in the tank. *Answers: 816 kJ/kg, 655 K*

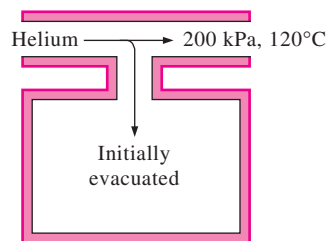

FIGURE P5-124

**5-125** Consider an 8-L evacuated rigid bottle that is surrounded by the atmosphere at 100 kPa and 17°C. A valve at the neck of the bottle is now opened and the atmospheric air is allowed to flow into the bottle. The air trapped in the bottle eventually reaches thermal equilibrium with the atmosphere as a result of heat transfer through the wall of the bottle. The valve remains open during the process so that the trapped air also reaches mechanical equilibrium with the atmosphere. Determine the net heat transfer through the wall of the bottle during this filling process. *Answer:  $Q_{\text{out}} = 0.8 \text{ kJ}$*

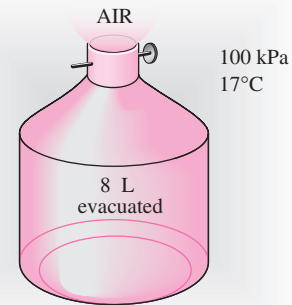

FIGURE P5-125

**5-126** An insulated rigid tank is initially evacuated. A valve is opened, and atmospheric air at 95 kPa and 17°C enters the tank until the pressure in the tank reaches 95 kPa, at which point the valve is closed. Determine the final temperature of the air in the tank. Assume constant specific heats. *Answer: 406 K*

**5-127** A 2-m<sup>3</sup> rigid tank initially contains air at 100 kPa and 22°C. The tank is connected to a supply line through a valve. Air is flowing in the supply line at 600 kPa and 22°C. The valve is opened, and air is allowed to enter the tank until the pressure in the tank reaches the line pressure, at which point the valve is closed. A thermometer placed in the tank indicates that the air temperature at the final state is 77°C. Determine (a) the mass of air that has entered the tank and (b) the amount of heat transfer. *Answers: (a) 9.58 kg, (b)  $Q_{\text{out}} = 339 \text{ kJ}$*

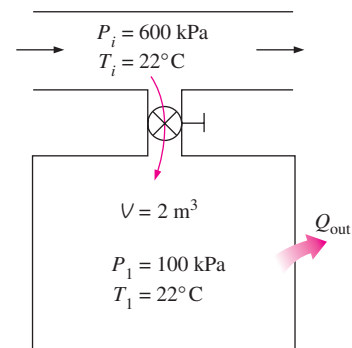

FIGURE P5-127

**5-128** A 0.2-m<sup>3</sup> rigid tank initially contains refrigerant-134a at 8°C. At this state, 70 percent of the mass is in the vapor phase, and the rest is in the liquid phase. The tank is connected by a valve to a supply line where refrigerant at 1 MPa and 100°C flows steadily. Now the valve is opened slightly, and the refrigerant is allowed to enter the tank. When the pressure in the tank reaches 800 kPa, the entire refrigerant in the

tank exists in the vapor phase only. At this point the valve is closed. Determine (a) the final temperature in the tank, (b) the mass of refrigerant that has entered the tank, and (c) the heat transfer between the system and the surroundings.

**5–129E** A 3-ft<sup>3</sup> rigid tank initially contains saturated water vapor at 300°F. The tank is connected by a valve to a supply line that carries steam at 200 psia and 400°F. Now the valve is opened, and steam is allowed to enter the tank. Heat transfer takes place with the surroundings such that the temperature in the tank remains constant at 300°F at all times. The valve is closed when it is observed that one-half of the volume of the tank is occupied by liquid water. Find (a) the final pressure in the tank, (b) the amount of steam that has entered the tank, and (c) the amount of heat transfer. *Answers: (a) 67.03 psia, (b) 85.74 lbm, (c) 80,900 Btu*

**5–130** A vertical piston–cylinder device initially contains 0.01 m<sup>3</sup> of steam at 200°C. The mass of the frictionless piston is such that it maintains a constant pressure of 500 kPa inside. Now steam at 1 MPa and 350°C is allowed to enter the cylinder from a supply line until the volume inside doubles. Neglecting any heat transfer that may have taken place during the process, determine (a) the final temperature of the steam in the cylinder and (b) the amount of mass that has entered. *Answers: (a) 261.7°C, (b) 0.0176 kg*

**5–131** An insulated, vertical piston–cylinder device initially contains 10 kg of water, 6 kg of which is in the vapor phase. The mass of the piston is such that it maintains a constant pressure of 200 kPa inside the cylinder. Now steam at 0.5 MPa and 350°C is allowed to enter the cylinder from a supply line until all the liquid in the cylinder has vaporized. Determine (a) the final temperature in the cylinder and (b) the mass of the steam that has entered. *Answers: (a) 120.2°C, (b) 19.07 kg*

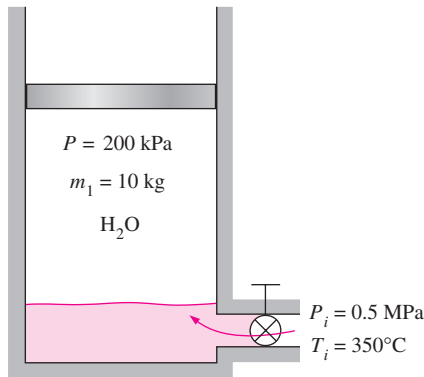

FIGURE P5–131

**5–132** A 0.12-m<sup>3</sup> rigid tank initially contains refrigerant-134a at 1 MPa and 100 percent quality. The tank is connected by a valve to a supply line that carries refrigerant-134a at 1.2 MPa and 36°C. Now the valve is opened, and the refrigerant is allowed to enter the tank. The valve is closed when it is

observed that the tank contains saturated liquid at 1.2 MPa. Determine (a) the mass of the refrigerant that has entered the tank and (b) the amount of heat transfer. *Answers: (a) 128.4 kg, (b) 1057 kJ*

**5–133** A 0.3-m<sup>3</sup> rigid tank is filled with saturated liquid water at 200°C. A valve at the bottom of the tank is opened, and liquid is withdrawn from the tank. Heat is transferred to the water such that the temperature in the tank remains constant. Determine the amount of heat that must be transferred by the time one-half of the total mass has been withdrawn.

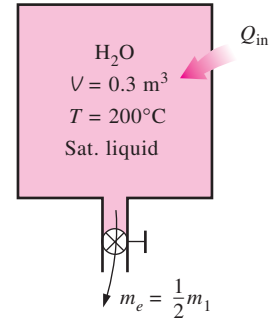

FIGURE P5–133

**5–134** A 0.12-m<sup>3</sup> rigid tank contains saturated refrigerant-134a at 800 kPa. Initially, 25 percent of the volume is occupied by liquid and the rest by vapor. A valve at the bottom of the tank is now opened, and liquid is withdrawn from the tank. Heat is transferred to the refrigerant such that the pressure inside the tank remains constant. The valve is closed when no liquid is left in the tank and vapor starts to come out. Determine the total heat transfer for this process. *Answer: 201.2 kJ*

**5–135E** A 4-ft<sup>3</sup> rigid tank contains saturated refrigerant-134a at 100 psia. Initially, 20 percent of the volume is occupied by liquid and the rest by vapor. A valve at the top of the tank is now opened, and vapor is allowed to escape slowly from the tank. Heat is transferred to the refrigerant such that the pressure inside the tank remains constant. The valve is closed when the last drop of liquid in the tank is vaporized. Determine the total heat transfer for this process.

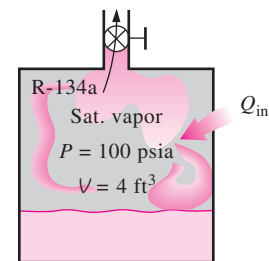
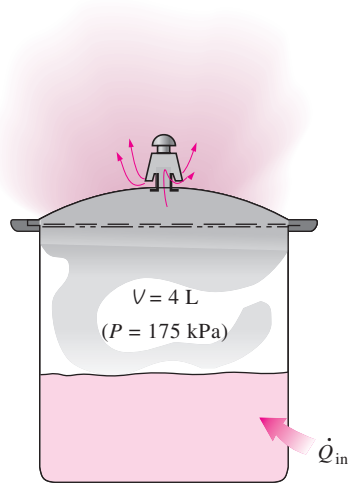

FIGURE P5–135E

**5–136** A 0.2-m<sup>3</sup> rigid tank equipped with a pressure regulator contains steam at 2 MPa and 300°C. The steam in the tank is now heated. The regulator keeps the steam pressure constant by letting out some steam, but the temperature inside rises. Determine the amount of heat transferred when the steam temperature reaches 500°C.

**5–137** A 4-L pressure cooker has an operating pressure of 175 kPa. Initially, one-half of the volume is filled with liquid and the other half with vapor. If it is desired that the pressure cooker not run out of liquid water for 1 h, determine the highest rate of heat transfer allowed.



**FIGURE P5–137**

**5–138** An insulated 0.08-m<sup>3</sup> tank contains helium at 2 MPa and 80°C. A valve is now opened, allowing some helium to escape. The valve is closed when one-half of the initial mass has escaped. Determine the final temperature and pressure in the tank. *Answers: 225 K, 637 kPa*

**5–139E** An insulated 60-ft<sup>3</sup> rigid tank contains air at 75 psia and 120°F. A valve connected to the tank is now opened, and air is allowed to escape until the pressure inside drops to 30 psia. The air temperature during this process is maintained

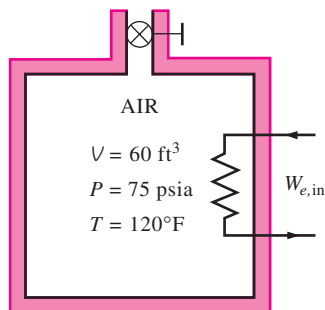
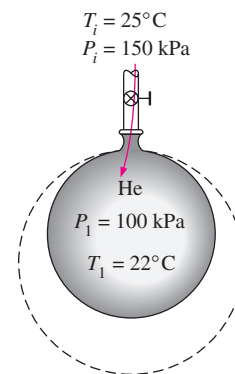

**FIGURE P5–139E**

constant by an electric resistance heater placed in the tank. Determine the electrical work done during this process.

**5–140** A vertical piston–cylinder device initially contains 0.2 m<sup>3</sup> of air at 20°C. The mass of the piston is such that it maintains a constant pressure of 300 kPa inside. Now a valve connected to the cylinder is opened, and air is allowed to escape until the volume inside the cylinder is decreased by one-half. Heat transfer takes place during the process so that the temperature of the air in the cylinder remains constant. Determine (a) the amount of air that has left the cylinder and (b) the amount of heat transfer. *Answers: (a) 0.357 kg, (b) 0*

**5–141** A balloon initially contains 65 m<sup>3</sup> of helium gas at atmospheric conditions of 100 kPa and 22°C. The balloon is connected by a valve to a large reservoir that supplies helium gas at 150 kPa and 25°C. Now the valve is opened, and helium is allowed to enter the balloon until pressure equilibrium with the helium at the supply line is reached. The material of the balloon is such that its volume increases linearly with pressure. If no heat transfer takes place during this process, determine the final temperature in the balloon. *Answer: 334 K*



**FIGURE P5–141**

**5–142** An insulated vertical piston–cylinder device initially contains 0.8 m<sup>3</sup> of refrigerant-134a at 1.2 MPa and 120°C. A linear spring at this point applies full force to the piston. A valve connected to the cylinder is now opened, and refrigerant

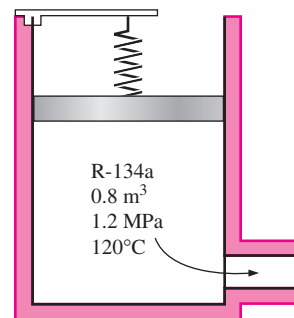

**FIGURE P5–142**

is allowed to escape. The spring unwinds as the piston moves down, and the pressure and volume drop to 0.6 MPa and 0.5 m<sup>3</sup> at the end of the process. Determine (a) the amount of refrigerant that has escaped and (b) the final temperature of the refrigerant.

**5-143** A 2-m<sup>3</sup> rigid insulated tank initially containing saturated water vapor at 1 MPa is connected through a valve to a supply line that carries steam at 400°C. Now the valve is opened, and steam is allowed to flow slowly into the tank until the pressure in the tank rises to 2 MPa. At this instant the tank temperature is measured to be 300°C. Determine the mass of the steam that has entered and the pressure of the steam in the supply line.

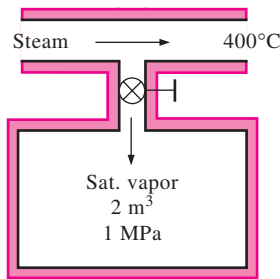

FIGURE P5-143

**5-144** A piston–cylinder device initially contains 0.6 kg of steam with a volume of 0.1 m<sup>3</sup>. The mass of the piston is such that it maintains a constant pressure of 800 kPa. The cylinder is connected through a valve to a supply line that carries steam at 5 MPa and 500°C. Now the valve is opened and steam is allowed to flow slowly into the cylinder until the volume of the cylinder doubles and the temperature in the cylinder reaches 250°C, at which point the valve is closed. Determine (a) the mass of steam that has entered and (b) the amount of heat transfer.

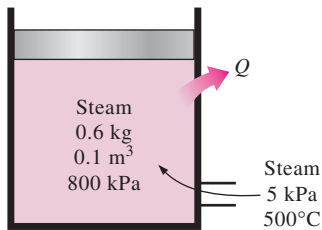

FIGURE P5-144

**Review Problems**

**5-145** A  $D_0 = 10$ -m-diameter tank is initially filled with water 2 m above the center of a  $D = 10$ -cm-diameter valve near the bottom. The tank surface is open to the atmosphere, and the tank drains through a  $L = 100$ -m-long pipe connected to the valve. The friction factor of the pipe is given

to be  $f = 0.015$ , and the discharge velocity is expressed as  $V = \sqrt{\frac{2gz}{1.5 + fL/D}}$  where  $z$  is the water height above the center of the valve. Determine (a) the initial discharge velocity from the tank and (b) the time required to empty the tank. The tank can be considered to be empty when the water level drops to the center of the valve.

**5-146** Underground water is being pumped into a pool whose cross section is 3 m  $\times$  4 m while water is discharged through a 5-cm-diameter orifice at a constant average velocity of 5 m/s. If the water level in the pool rises at a rate of 1.5 cm/min, determine the rate at which water is supplied to the pool, in m<sup>3</sup>/s.

**5-147** The velocity of a liquid flowing in a circular pipe of radius  $R$  varies from zero at the wall to a maximum at the pipe center. The velocity distribution in the pipe can be represented as  $V(r)$ , where  $r$  is the radial distance from the pipe center. Based on the definition of mass flow rate  $\dot{m}$ , obtain a relation for the average velocity in terms of  $V(r)$ ,  $R$ , and  $r$ .

**5-148** Air at 4.18 kg/m<sup>3</sup> enters a nozzle that has an inlet-to-exit area ratio of 2:1 with a velocity of 120 m/s and leaves with a velocity of 380 m/s. Determine the density of air at the exit. *Answer: 2.64 kg/m<sup>3</sup>*

**5-149** The air in a 6-m  $\times$  5-m  $\times$  4-m hospital room is to be completely replaced by conditioned air every 15 min. If the average air velocity in the circular air duct leading to the room is not to exceed 5 m/s, determine the minimum diameter of the duct.

**5-150** A long roll of 1-m-wide and 0.5-cm-thick 1-Mn manganese steel plate ( $\rho = 7854$  kg/m<sup>3</sup>) coming off a furnace is to be quenched in an oil bath to a specified temperature. If the metal sheet is moving at a steady velocity of 10 m/min, determine the mass flow rate of the steel plate through the oil bath.

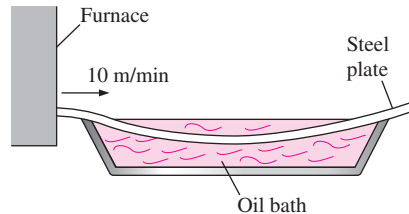

FIGURE P5-150

**5-151E** It is well established that indoor air quality (IAQ) has a significant effect on general health and productivity of employees at a workplace. A recent study showed that enhancing IAQ by increasing the building ventilation from 5 cfm (cubic feet per minute) to 20 cfm increased the productivity by 0.25 percent, valued at \$90 per person per year, and decreased the respiratory illnesses by 10 percent for an average annual savings of \$39 per person while increasing the annual energy consumption by \$6 and the equipment cost by

about \$4 per person per year (*ASHRAE Journal*, December 1998). For a workplace with 120 employees, determine the net monetary benefit of installing an enhanced IAQ system to the employer per year. *Answer: \$14,280/yr*

**5-152** Air enters a pipe at 50°C and 200 kPa and leaves at 40°C and 150 kPa. It is estimated that heat is lost from the pipe in the amount of 3.3 kJ per kg of air flowing in the pipe. The diameter ratio for the pipe is  $D_1/D_2 = 1.8$ . Using constant specific heats for air, determine the inlet and exit velocities of the air. *Answers: 28.6 m/s, 120 m/s*

**5-153** In a single-flash geothermal power plant, geothermal water enters the flash chamber (a throttling valve) at 230°C as a saturated liquid at a rate of 50 kg/s. The steam resulting from the flashing process enters a turbine and leaves at 20 kPa with a moisture content of 5 percent. Determine the temperature of the steam after the flashing process and the power output from the turbine if the pressure of the steam at the exit of the flash chamber is (a) 1 MPa, (b) 500 kPa, (c) 100 kPa, (d) 50 kPa.

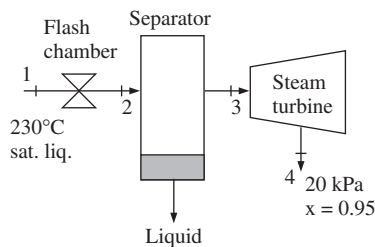

FIGURE P5-153

**5-154** The hot-water needs of a household are met by a 60-L electric water heater whose heaters are rated at 1.6 kW. The hot-water tank is initially full with hot water at 80°C. Somebody takes a shower by mixing a constant flow of hot water from the tank with cold water at 20°C at a rate of 0.06 kg/s. After a shower period of 8 min, the water temperature in the tank is measured to drop to 60°C. The heater remained on during the shower and hot water withdrawn from the tank is replaced by cold water at the same flow rate. Determine the mass flow rate of hot water withdrawn from the tank during the shower and the average temperature of mixed water used for the shower.

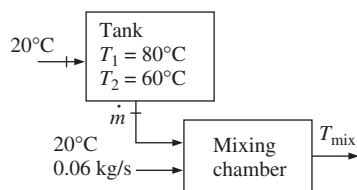

FIGURE P5-154

**5-155** In a gas-fired boiler, water is boiled at 150°C by hot gases flowing through a stainless steel pipe submerged in

water. If the rate of heat transfer from the hot gases to water is 74 kJ/s, determine the rate of evaporation of water.

**5-156** Cold water enters a steam generator at 20°C and leaves as saturated vapor at 150°C. Determine the fraction of heat used in the steam generator to preheat the liquid water from 20°C to the saturation temperature of 150°C.

**5-157** Cold water enters a steam generator at 20°C and leaves as saturated vapor at the boiler pressure. At what pressure will the amount of heat needed to preheat the water to saturation temperature be equal to the heat needed to vaporize the liquid at the boiler pressure?

**5-158** Saturated steam at 1 atm condenses on a vertical plate that is maintained at 90°C by circulating cooling water through the other side. If the rate of heat transfer by condensation to the plate is 180 kJ/s, determine the rate at which the condensate drips off the plate at the bottom.

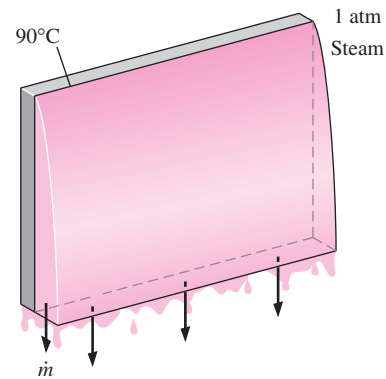

FIGURE P5-158

**5-159** Water is boiled at 100°C electrically by a 3-kW resistance wire. Determine the rate of evaporation of water.

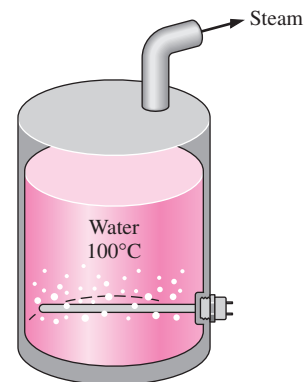

FIGURE P5-159

**5-160** Two streams of the same ideal gas having different mass flow rates and temperatures are mixed in a steady-flow, adiabatic mixing device. Assuming constant specific heats,

find the simplest expression for the mixture temperature written in the form

$$T_3 = f\left(\frac{\dot{m}_1}{\dot{m}_3}, \frac{\dot{m}_2}{\dot{m}_3}, T_1, T_2\right)$$



FIGURE P5-160

**5-161** An ideal gas expands in an adiabatic turbine from 1200 K, 600 kPa to 700 K. Determine the turbine inlet volume flow rate of the gas, in  $\text{m}^3/\text{s}$ , required to produce turbine work output at the rate of 200 kW. The average values of the specific heats for this gas over the temperature range are  $c_p = 1.13 \text{ kJ/kg} \cdot \text{K}$  and  $c_v = 0.83 \text{ kJ/kg} \cdot \text{K}$ .  $R = 0.30 \text{ kJ/kg} \cdot \text{K}$ .

**5-162** Consider two identical buildings: one in Los Angeles, California, where the atmospheric pressure is 101 kPa and the other in Denver, Colorado, where the atmospheric pressure is 83 kPa. Both buildings are maintained at  $21^\circ\text{C}$ , and the infiltration rate for both buildings is 1.2 air changes per hour (ACH). That is, the entire air in the building is replaced completely by the outdoor air 1.2 times per hour on a day when the outdoor temperature at both locations is  $10^\circ\text{C}$ . Disregarding latent heat, determine the ratio of the heat losses by infiltration at the two cities.

**5-163** The ventilating fan of the bathroom of a building has a volume flow rate of 30 L/s and runs continuously. The

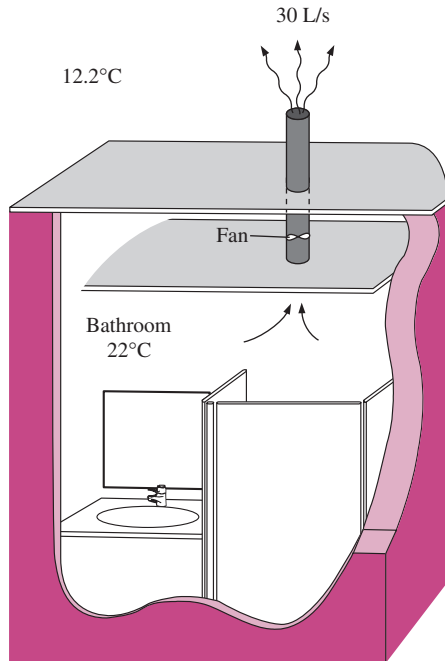

FIGURE P5-163

building is located in San Francisco, California, where the average winter temperature is  $12.2^\circ\text{C}$ , and is maintained at  $22^\circ\text{C}$  at all times. The building is heated by electricity whose unit cost is  $\$0.09/\text{kWh}$ . Determine the amount and cost of the heat “vented out” per month in winter.

**5-164** Consider a large classroom on a hot summer day with 150 students, each dissipating 60 W of sensible heat. All the lights, with 6.0 kW of rated power, are kept on. The room has no external walls, and thus heat gain through the walls and the roof is negligible. Chilled air is available at  $15^\circ\text{C}$ , and the temperature of the return air is not to exceed  $25^\circ\text{C}$ . Determine the required flow rate of air, in  $\text{kg/s}$ , that needs to be supplied to the room to keep the average temperature of the room constant. *Answer: 1.49 kg/s*

**5-165** Chickens with an average mass of 2.2 kg and average specific heat of  $3.54 \text{ kJ/kg} \cdot ^\circ\text{C}$  are to be cooled by chilled water that enters a continuous-flow-type immersion chiller at  $0.5^\circ\text{C}$ . Chickens are dropped into the chiller at a uniform temperature of  $15^\circ\text{C}$  at a rate of 500 chickens per hour and are cooled to an average temperature of  $3^\circ\text{C}$  before they are taken out. The chiller gains heat from the surroundings at a rate of 200 kJ/h. Determine (a) the rate of heat removal from the chickens, in kW, and (b) the mass flow rate of water, in  $\text{kg/s}$ , if the temperature rise of water is not to exceed  $2^\circ\text{C}$ .

**5-166** Repeat Prob. 5-165 assuming heat gain of the chiller is negligible.

**5-167** In a dairy plant, milk at  $4^\circ\text{C}$  is pasteurized continuously at  $72^\circ\text{C}$  at a rate of 12 L/s for 24 h a day and 365 days a year. The milk is heated to the pasteurizing temperature by hot water heated in a natural-gas-fired boiler that has an efficiency of 82 percent. The pasteurized milk is then cooled by cold water at  $18^\circ\text{C}$  before it is finally refrigerated back to  $4^\circ\text{C}$ . To save energy and money, the plant installs a regenerator that has an effectiveness of 82 percent. If the cost of natural gas is  $\$1.10/\text{therm}$  (1 therm = 105,500 kJ), determine how much energy and money the regenerator will save this company per year.

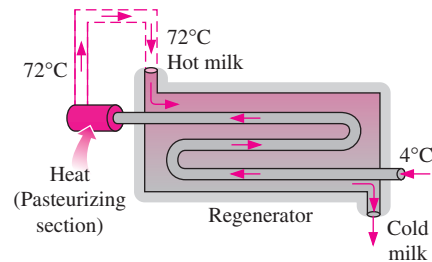

FIGURE P5-167

**5-168E** A refrigeration system is being designed to cool eggs ( $\rho = 67.4 \text{ lbm}/\text{ft}^3$  and  $c_p = 0.80 \text{ Btu}/\text{lbm} \cdot ^\circ\text{F}$ ) with an average mass of 0.14 lbm from an initial temperature of  $90^\circ\text{F}$

to a final average temperature of 50°F by air at 34°F at a rate of 10,000 eggs per hour. Determine (a) the rate of heat removal from the eggs, in Btu/h and (b) the required volume flow rate of air, in ft<sup>3</sup>/h, if the temperature rise of air is not to exceed 10°F.

**5-169** The heat of hydration of dough, which is 15 kJ/kg, will raise its temperature to undesirable levels unless some cooling mechanism is utilized. A practical way of absorbing the heat of hydration is to use refrigerated water when kneading the dough. If a recipe calls for mixing 2 kg of flour with 1 kg of water, and the temperature of the city water is 15°C, determine the temperature to which the city water must be cooled before mixing in order for the water to absorb the entire heat of hydration when the water temperature rises to 15°C. Take the specific heats of the flour and the water to be 1.76 and 4.18 kJ/kg · °C, respectively. *Answer: 4.2°C*

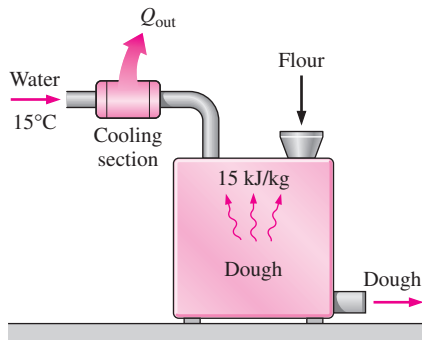

FIGURE P5-169

**5-170** A glass bottle washing facility uses a well-agitated hot-water bath at 55°C that is placed on the ground. The bottles enter at a rate of 800 per minute at an ambient temperature of 20°C and leave at the water temperature. Each bottle has a mass of 150 g and removes 0.2 g of water as it leaves the bath wet. Make-up water is supplied at 15°C. Disregarding any heat losses from the outer surfaces of the bath, determine the rate at which (a) water and (b) heat must be supplied to maintain steady operation.

**5-171** Repeat Prob. 5-170 for a water bath temperature of 50°C.

**5-172** Long aluminum wires of diameter 3 mm ( $\rho = 2702 \text{ kg/m}^3$  and  $c_p = 0.896 \text{ kJ/kg} \cdot ^\circ\text{C}$ ) are extruded at a tem-

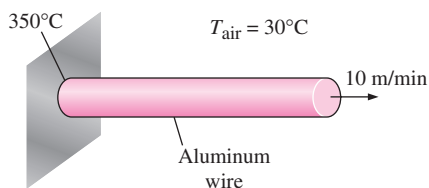

FIGURE P5-172

perature of 350°C and are cooled to 50°C in atmospheric air at 30°C. If the wire is extruded at a velocity of 10 m/min, determine the rate of heat transfer from the wire to the extrusion room.

**5-173** Repeat Prob. 5-172 for a copper wire ( $\rho = 8950 \text{ kg/m}^3$  and  $c_p = 0.383 \text{ kJ/kg} \cdot ^\circ\text{C}$ ).

**5-174** Steam at 40°C condenses on the outside of a 5-m-long, 3-cm-diameter thin horizontal copper tube by cooling water that enters the tube at 25°C at an average velocity of 2 m/s and leaves at 35°C. Determine the rate of condensation of steam. *Answer: 0.0245 kg/s*

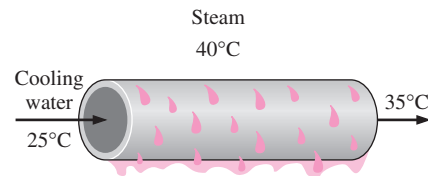

FIGURE P5-174

**5-175E** The condenser of a steam power plant operates at a pressure of 0.95 psia. The condenser consists of 144 horizontal tubes arranged in a 12 × 12 square array. Steam condenses on the outer surfaces of the tubes whose inner and outer diameters are 1 in and 1.2 in, respectively. If steam is to be condensed at a rate of 6800 lbm/h and the temperature rise of the cooling water is limited to 8°F, determine (a) the rate of heat transfer from the steam to the cooling water and (b) the average velocity of the cooling water through the tubes.

**5-176** Saturated refrigerant-134a vapor at 34°C is to be condensed as it flows in a 1-cm-diameter tube at a rate of 0.1 kg/min. Determine the rate of heat transfer from the refrigerant. What would your answer be if the condensed refrigerant is cooled to 20°C?

**5-177E** The average atmospheric pressure in Spokane, Washington (elevation = 2350 ft), is 13.5 psia, and the average winter temperature is 36.5°F. The pressurization test of a 9-ft-high, 3000-ft<sup>2</sup> older home revealed that the seasonal average infiltration rate of the house is 2.2 air changes per hour (ACH). That is, the entire air in the house is replaced completely 2.2 times per hour by the outdoor air. It is suggested that the infiltration rate of the house can be reduced by half to 1.1 ACH by winterizing the doors and the windows. If the house is heated by natural gas whose unit cost is \$1.24/therm and the heating season can be taken to be six months, determine how much the home owner will save from the heating costs per year by this winterization project. Assume the house is maintained at 72°F at all times and the efficiency of the furnace is 0.65. Also assume the latent heat load during the heating season to be negligible.

**5-178** Determine the rate of sensible heat loss from a building due to infiltration if the outdoor air at  $-5^\circ\text{C}$  and 90 kPa

enters the building at a rate of 35 L/s when the indoors is maintained at 20°C.

**5-179** The maximum flow rate of standard shower heads is about 3.5 gpm (13.3 L/min) and can be reduced to 2.75 gpm (10.5 L/min) by switching to low-flow shower heads that are equipped with flow controllers. Consider a family of four, with each person taking a 5 min shower every morning. City water at 15°C is heated to 55°C in an electric water heater and tempered to 42°C by cold water at the T-elbow of the shower before being routed to the shower heads. Assuming a constant specific heat of 4.18 kJ/kg · °C for water, determine (a) the ratio of the flow rates of the hot and cold water as they enter the T-elbow and (b) the amount of electricity that will be saved per year, in kWh, by replacing the standard shower heads by the low-flow ones.

**5-180**  Reconsider Prob. 5-179. Using EES (or other) software, investigate the effect of the inlet temperature of cold water on the energy saved by using the low-flow shower head. Let the inlet temperature vary from 10°C to 20°C. Plot the electric energy savings against the water inlet temperature, and discuss the results.

**5-181** A fan is powered by a 0.5-hp motor and delivers air at a rate of 85 m<sup>3</sup>/min. Determine the highest value for the average velocity of air mobilized by the fan. Take the density of air to be 1.18 kg/m<sup>3</sup>.

**5-182** An air-conditioning system requires airflow at the main supply duct at a rate of 180 m<sup>3</sup>/min. The average velocity of air in the circular duct is not to exceed 10 m/s to avoid excessive vibration and pressure drops. Assuming the fan converts 70 percent of the electrical energy it consumes into kinetic energy of air, determine the size of the electric motor needed to drive the fan and the diameter of the main duct. Take the density of air to be 1.20 kg/m<sup>3</sup>.

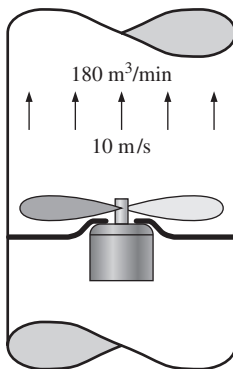
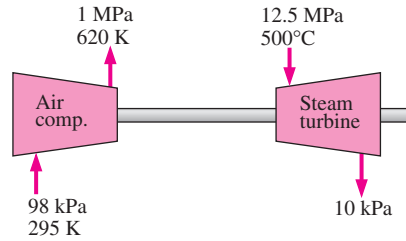

**FIGURE P5-182**

**5-183** Consider an evacuated rigid bottle of volume  $V$  that is surrounded by the atmosphere at pressure  $P_0$  and temperature  $T_0$ . A valve at the neck of the bottle is now opened and the atmospheric air is allowed to flow into the bottle. The air

trapped in the bottle eventually reaches thermal equilibrium with the atmosphere as a result of heat transfer through the wall of the bottle. The valve remains open during the process so that the trapped air also reaches mechanical equilibrium with the atmosphere. Determine the net heat transfer through the wall of the bottle during this filling process in terms of the properties of the system and the surrounding atmosphere.

**5-184** An adiabatic air compressor is to be powered by a direct-coupled adiabatic steam turbine that is also driving a generator. Steam enters the turbine at 12.5 MPa and 500°C at a rate of 25 kg/s and exits at 10 kPa and a quality of 0.92. Air enters the compressor at 98 kPa and 295 K at a rate of 10 kg/s and exits at 1 MPa and 620 K. Determine the net power delivered to the generator by the turbine.



**FIGURE P5-184**

**5-185** Water flows through a shower head steadily at a rate of 10 L/min. An electric resistance heater placed in the water pipe heats the water from 16 to 43°C. Taking the density of water to be 1 kg/L, determine the electric power input to the heater, in kW.

In an effort to conserve energy, it is proposed to pass the drained warm water at a temperature of 39°C through a heat exchanger to preheat the incoming cold water. If the heat exchanger has an effectiveness of 0.50 (that is, it recovers

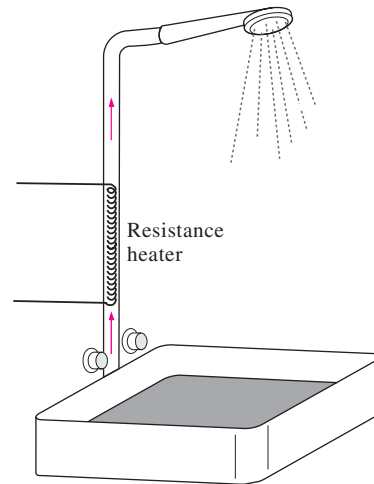

**FIGURE P5-185**

only half of the energy that can possibly be transferred from the drained water to incoming cold water), determine the electric power input required in this case. If the price of the electric energy is 8.5 ¢/kWh, determine how much money is saved during a 10-min shower as a result of installing this heat exchanger.

**5–186**  Reconsider Prob. 5–185. Using EES (or other) software, investigate the effect of the heat exchanger effectiveness on the money saved. Let effectiveness range from 20 to 90 percent. Plot the money saved against the effectiveness, and discuss the results.

**5–187**  Steam enters a turbine steadily at 10 MPa and 550°C with a velocity of 60 m/s and leaves at 25 kPa with a quality of 95 percent. A heat loss of 30 kJ/kg occurs during the process. The inlet area of the turbine is 150 cm<sup>2</sup>, and the exit area is 1400 cm<sup>2</sup>. Determine (a) the mass flow rate of the steam, (b) the exit velocity, and (c) the power output.

**5–188**  Reconsider Prob. 5–187. Using EES (or other) software, investigate the effects of turbine exit area and turbine exit pressure on the exit velocity and power output of the turbine. Let the exit pressure vary from 10 to 50 kPa (with the same quality), and the exit area to vary from 1000 to 3000 cm<sup>2</sup>. Plot the exit velocity and the power outlet against the exit pressure for the exit areas of 1000, 2000, and 3000 cm<sup>2</sup>, and discuss the results.

**5–189E** Refrigerant-134a enters an adiabatic compressor at 15 psia and 20°F with a volume flow rate of 10 ft<sup>3</sup>/s and leaves at a pressure of 100 psia. The power input to the compressor is 45 hp. Find (a) the mass flow rate of the refrigerant and (b) the exit temperature.

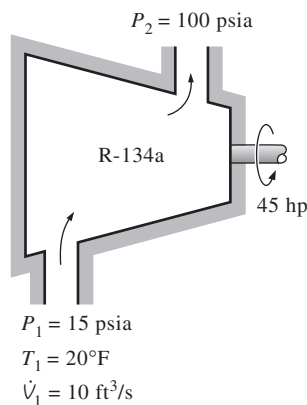

FIGURE P5–189E

**5–190** In large gas-turbine power plants, air is preheated by the exhaust gases in a heat exchanger called the *regenerator* before it enters the combustion chamber. Air enters the regenerator at 1 MPa and 550 K at a mass flow rate of 800 kg/min. Heat is transferred to the air at a rate of 3200 kJ/s. Exhaust

gases enter the regenerator at 140 kPa and 800 K and leave at 130 kPa and 600 K. Treating the exhaust gases as air, determine (a) the exit temperature of the air and (b) the mass flow rate of exhaust gases. *Answers: (a) 775 K, (b) 14.9 kg/s*

**5–191** It is proposed to have a water heater that consists of an insulated pipe of 5-cm diameter and an electric resistor inside. Cold water at 20°C enters the heating section steadily at a rate of 30 L/min. If water is to be heated to 55°C, determine (a) the power rating of the resistance heater and (b) the average velocity of the water in the pipe.

**5–192** In large steam power plants, the feedwater is frequently heated in a closed feedwater heater by using steam extracted from the turbine at some stage. Steam enters the feedwater heater at 1 MPa and 200°C and leaves as saturated liquid at the same pressure. Feedwater enters the heater at 2.5 MPa and 50°C and leaves at 10°C below the exit temperature of the steam. Determine the ratio of the mass flow rates of the extracted steam and the feedwater.

**5–193** A building with an internal volume of 400 m<sup>3</sup> is to be heated by a 30-kW electric resistance heater placed in the duct inside the building. Initially, the air in the building is at 14°C, and the local atmospheric pressure is 95 kPa. The building is losing heat to the surroundings at a steady rate of 450 kJ/min. Air is forced to flow through the duct and the heater steadily by a 250-W fan, and it experiences a temperature rise of 5°C each time it passes through the duct, which may be assumed to be adiabatic.

(a) How long will it take for the air inside the building to reach an average temperature of 24°C?  
 (b) Determine the average mass flow rate of air through the duct. *Answers: (a) 146 s, (b) 6.02 kg/s*

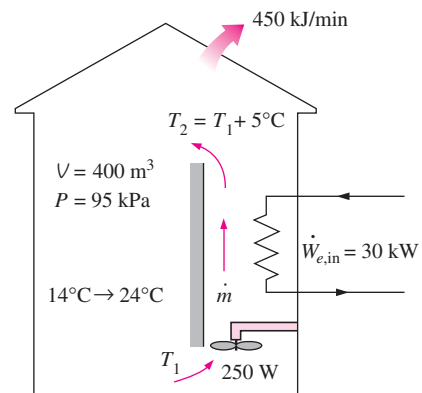



FIGURE P5–193

**5–194**  An insulated vertical piston–cylinder device initially contains 0.2 m<sup>3</sup> of air at 200 kPa and 22°C. At this state, a linear spring touches the piston but exerts no force on it. The cylinder is connected by a valve to a line that supplies air at 800 kPa and 22°C. The valve is

opened, and air from the high-pressure line is allowed to enter the cylinder. The valve is turned off when the pressure inside the cylinder reaches 600 kPa. If the enclosed volume inside the cylinder doubles during this process, determine (a) the mass of air that entered the cylinder, and (b) the final temperature of the air inside the cylinder.

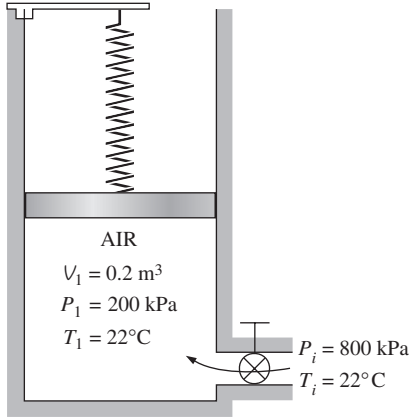

FIGURE P5-194

**5-195** A piston-cylinder device initially contains 2 kg of refrigerant-134a at 800 kPa and 80°C. At this state, the piston is touching on a pair of stops at the top. The mass of the piston is such that a 500-kPa pressure is required to move it. A valve at the bottom of the tank is opened, and R-134a is withdrawn from the cylinder. After a while, the piston is observed to move and the valve is closed when half of the refrigerant is withdrawn from the tank and the temperature in the tank drops to 20°C. Determine (a) the work done and (b) the heat transfer. *Answers: (a) 11.6 kJ, (b) 60.7 kJ*

**5-196** A piston-cylinder device initially contains 1.2 kg of air at 700 kPa and 200°C. At this state, the piston is touching on a pair of stops. The mass of the piston is such that 600-kPa pressure is required to move it. A valve at the bottom of the tank is opened, and air is withdrawn from the cylinder. The valve is closed when the volume of the cylinder decreases to 80 percent of the initial volume. If it is estimated that 40 kJ of heat is lost from the cylinder, determine (a) the final temperature of the air in the cylinder, (b) the amount of mass that

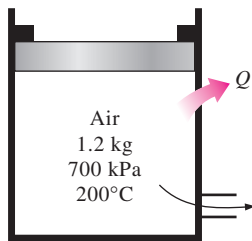

FIGURE P5-196

has escaped from the cylinder, and (c) the work done. Use constant specific heats at the average temperature.

**5-197** The pump of a water distribution system is powered by a 15-kW electric motor whose efficiency is 90 percent. The water flow rate through the pump is 50 L/s. The diameters of the inlet and outlet pipes are the same, and the elevation difference across the pump is negligible. If the pressures at the inlet and outlet of the pump are measured to be 100 kPa and 300 kPa (absolute), respectively, determine (a) the mechanical efficiency of the pump and (b) the temperature rise of water as it flows through the pump due to the mechanical inefficiency. *Answers: (a) 74.1 percent, (b) 0.017°C*

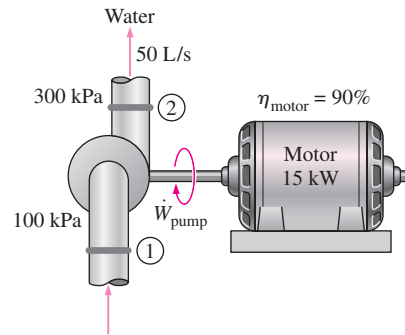

FIGURE P5-197

**5-198** Steam enters a nozzle with a low velocity at 150°C and 200 kPa, and leaves as a saturated vapor at 75 kPa. There is a heat transfer from the nozzle to the surroundings in the amount of 26 kJ for every kilogram of steam flowing through the nozzle. Determine (a) the exit velocity of the steam and (b) the mass flow rate of the steam at the nozzle entrance if the nozzle exit area is 0.001 m<sup>2</sup>.

**5-199** The turbocharger of an internal combustion engine consists of a turbine and a compressor. Hot exhaust gases flow through the turbine to produce work and the work output from the turbine is used as the work input to the compressor. The pressure of ambient air is increased as it flows through the compressor before it enters the engine cylinders. Thus, the purpose of a turbocharger is to increase the pressure of air so that

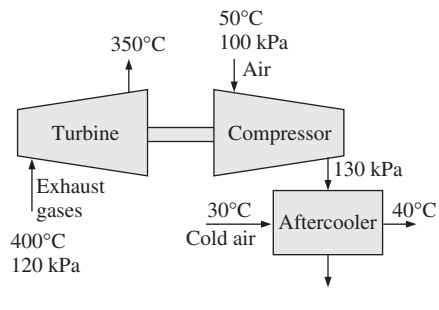

FIGURE P5-199

more air gets into the cylinder. Consequently, more fuel can be burned and more power can be produced by the engine.

In a turbocharger, exhaust gases enter the turbine at 400°C and 120 kPa at a rate of 0.02 kg/s and leave at 350°C. Air enters the compressor at 50°C and 100 kPa and leaves at 130 kPa at a rate of 0.018 kg/s. The compressor increases the air pressure with a side effect: It also increases the air temperature, which increases the possibility of a gasoline engine to experience an engine knock. To avoid this, an aftercooler is placed after the compressor to cool the warm air by cold ambient air before it enters the engine cylinders. It is estimated that the aftercooler must decrease the air temperature below 80°C if knock is to be avoided. The cold ambient air enters the aftercooler at 30°C and leaves at 40°C. Disregarding any frictional losses in the turbine and the compressor and treating the exhaust gases as air, determine (a) the temperature of the air at the compressor outlet and (b) the minimum volume flow rate of ambient air required to avoid knock.

### Fundamentals of Engineering (FE) Exam Problems

**5-200** Steam is accelerated by a nozzle steadily from a low velocity to a velocity of 210 m/s at a rate of 3.2 kg/s. If the temperature and pressure of the steam at the nozzle exit are 400°C and 2 MPa, the exit area of the nozzle is

- (a) 24.0 cm<sup>2</sup>                      (d) 152 cm<sup>2</sup>  
 (b) 8.4 cm<sup>2</sup>                        (e) 23.0 cm<sup>2</sup>  
 (c) 10.2 cm<sup>2</sup>

**5-201** Steam enters a diffuser steadily at 0.5 MPa, 300°C, and 122 m/s at a rate of 3.5 kg/s. The inlet area of the diffuser is

- (a) 15 cm<sup>2</sup>                         (d) 150 cm<sup>2</sup>  
 (b) 50 cm<sup>2</sup>                        (e) 190 cm<sup>2</sup>  
 (c) 105 cm<sup>2</sup>

**5-202** An adiabatic heat exchanger is used to heat cold water at 15°C entering at a rate of 5 kg/s by hot air at 90°C entering also at a rate of 5 kg/s. If the exit temperature of hot air is 20°C, the exit temperature of cold water is

- (a) 27°C                            (d) 85°C  
 (b) 32°C                            (e) 90°C  
 (c) 52°C

**5-203** A heat exchanger is used to heat cold water at 15°C entering at a rate of 2 kg/s by hot air at 100°C entering at a rate of 3 kg/s. The heat exchanger is not insulated and is losing heat at a rate of 40 kJ/s. If the exit temperature of hot air is 20°C, the exit temperature of cold water is

- (a) 44°C                            (d) 72°C  
 (b) 49°C                            (e) 95°C  
 (c) 39°C

**5-204** An adiabatic heat exchanger is used to heat cold water at 15°C entering at a rate of 5 kg/s by hot water at 90°C entering at a rate of 4 kg/s. If the exit temperature of hot water is 50°C, the exit temperature of cold water is

- (a) 42°C                            (d) 78°C  
 (b) 47°C                            (e) 90°C  
 (c) 55°C

**5-205** In a shower, cold water at 10°C flowing at a rate of 5 kg/min is mixed with hot water at 60°C flowing at a rate of 2 kg/min. The exit temperature of the mixture is

- (a) 24.3°C                         (d) 44.3°C  
 (b) 35.0°C                         (e) 55.2°C  
 (c) 40.0°C

**5-206** In a heating system, cold outdoor air at 10°C flowing at a rate of 6 kg/min is mixed adiabatically with heated air at 70°C flowing at a rate of 3 kg/min. The exit temperature of the mixture is

- (a) 30°C                            (d) 55°C  
 (b) 40°C                            (e) 85°C  
 (c) 45°C

**5-207** Hot combustion gases (assumed to have the properties of air at room temperature) enter a gas turbine at 1 MPa and 1500 K at a rate of 0.1 kg/s, and exit at 0.2 MPa and 900 K. If heat is lost from the turbine to the surroundings at a rate of 15 kJ/s, the power output of the gas turbine is

- (a) 15 kW                         (d) 60 kW  
 (b) 30 kW                         (e) 75 kW  
 (c) 45 kW

**5-208** Steam expands in a turbine from 4 MPa and 500°C to 0.5 MPa and 250°C at a rate of 1350 kg/h. Heat is lost from the turbine at a rate of 25 kJ/s during the process. The power output of the turbine is

- (a) 157 kW                        (d) 287 kW  
 (b) 207 kW                        (e) 246 kW  
 (c) 182 kW

**5-209** Steam is compressed by an adiabatic compressor from 0.2 MPa and 150°C to 2.5 MPa and 250°C at a rate of 1.30 kg/s. The power input to the compressor is

- (a) 144 kW                        (d) 717 kW  
 (b) 234 kW                        (e) 901 kW  
 (c) 438 kW

**5-210** Refrigerant-134a is compressed by a compressor from the saturated vapor state at 0.14 MPa to 1.2 MPa and 70°C at a rate of 0.108 kg/s. The refrigerant is cooled at a rate of 1.10 kJ/s during compression. The power input to the compressor is

- (a) 5.54 kW                        (d) 7.74 kW  
 (b) 7.33 kW                        (e) 8.13 kW  
 (c) 6.64 kW

**5-211** Refrigerant-134a expands in an adiabatic turbine from 1.2 MPa and 100°C to 0.18 MPa and 50°C at a rate of 1.25 kg/s. The power output of the turbine is

- (a) 46.3 kW                        (d) 89.2 kW  
 (b) 66.4 kW                        (e) 112.0 kW  
 (c) 72.7 kW

**5–212** Refrigerant-134a at 1.4 MPa and 90°C is throttled to a pressure of 0.6 MPa. The temperature of the refrigerant after throttling is

- (a) 22°C                      (d) 80°C  
 (b) 56°C                      (e) 90°C  
 (c) 82°C

**5–213** Air at 20°C and 5 atm is throttled by a valve to 2 atm. If the valve is adiabatic and the change in kinetic energy is negligible, the exit temperature of air will be

- (a) 10°C                      (d) 20°C  
 (b) 14°C                      (e) 24°C  
 (c) 17°C

**5–214** Steam at 1 MPa and 300°C is throttled adiabatically to a pressure of 0.4 MPa. If the change in kinetic energy is negligible, the specific volume of the steam after throttling is

- (a) 0.358 m<sup>3</sup>/kg              (d) 0.646 m<sup>3</sup>/kg  
 (b) 0.233 m<sup>3</sup>/kg              (e) 0.655 m<sup>3</sup>/kg  
 (c) 0.375 m<sup>3</sup>/kg

**5–215** Air is to be heated steadily by an 8-kW electric resistance heater as it flows through an insulated duct. If the air enters at 50°C at a rate of 2 kg/s, the exit temperature of air is

- (a) 46.0°C                      (d) 55.4°C  
 (b) 50.0°C                      (e) 58.0°C  
 (c) 54.0°C

**5–216** Saturated water vapor at 50°C is to be condensed as it flows through a tube at a rate of 0.35 kg/s. The condensate leaves the tube as a saturated liquid at 50°C. The rate of heat transfer from the tube is

- (a) 73 kJ/s                      (d) 834 kJ/s  
 (b) 980 kJ/s                      (e) 907 kJ/s  
 (c) 2380 kJ/s

## Design and Essay Problems

**5–217** Design a 1200-W electric hair dryer such that the air temperature and velocity in the dryer will not exceed 50°C and 3 m/s, respectively.

**5–218** Design a scalding unit for slaughtered chickens to loosen their feathers before they are routed to feather-picking machines with a capacity of 1200 chickens per hour under the following conditions:

The unit will be of an immersion type filled with hot water at an average temperature of 53°C at all times. Chicken with an average mass of 2.2 kg and an average temperature of 36°C will be dipped into the tank, held in the water for 1.5 min, and taken out by a slow-moving conveyor. The chicken is expected to leave the tank 15 percent heavier as a result of the water that sticks to its surface. The center-to-center distance between chickens in any direction will be at least 30 cm. The tank can be as wide as 3 m and as high as 60 cm. The water is to be circulated through and heated by a natural gas furnace, but the temperature rise of water will not exceed 5°C as it passes through the furnace. The water loss is to be made up by the city water at an average temperature of 16°C. The walls and the floor of the tank are well-insulated. The unit operates 24 h a day and 6 days a week. Assuming reasonable values for the average properties, recommend reasonable values for (a) the mass flow rate of the makeup water that must be supplied to the tank, (b) the rate of heat transfer from the water to the chicken, in kW, (c) the size of the heating system in kJ/h, and (d) the operating cost of the scalding unit per month for a unit cost of \$1.12/therm of natural gas.