

1st Law Closed System

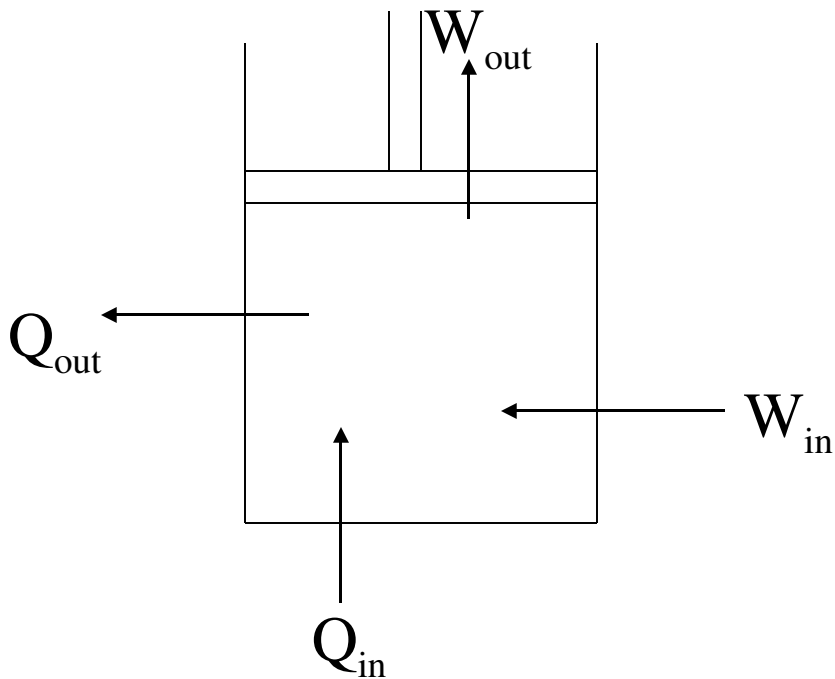

$$\Delta E = \underbrace{\Sigma Q - \Sigma W}$$

Net change
of system
energy

Net total energy transfer in
the form of heat and work

(ctd.)

- Recall that System Energy consists of:

$$E_{\text{system}} = U + KE + PE$$

or

$$\Delta E_{\text{system}} = \Delta U + \Delta KE + \Delta PE$$

thus;

$$Q - W = \Delta E_{\text{system}} = \Delta U + \Delta KE + \Delta PE$$

Or can be called as the

1st Law/Energy Balance of a Closed System;

$$Q - W = \Delta U + \Delta KE + \Delta PE$$

Net transfer
of energy

Energy storage in different
modes

(ctd.)

1st Law for Closed System in different forms;

$$Q - W = \Delta U + \Delta KE + \Delta PE \quad [\text{kJ}]$$

per unit mass;

$$q - w = \Delta u + \Delta ke + \Delta pe \quad [\text{kJ/kg}]$$

Rate form;

$$\dot{Q} - \dot{W} = \frac{dU}{dt} + \frac{d(KE)}{dt} + \frac{d(PE)}{dt} \quad [\text{kW}]$$

Cyclic Process $\Delta E = 0$

$$Q - W = 0$$

$$Q_{\text{cycle}} = W_{\text{cycle}}$$

$$\sum Q = \sum W$$

summary;

$$Q - W = \Delta U + \Delta KE + \Delta PE$$

